

Paroscientific, Inc.
Digiquartz® Pressure Instrumentation

User's Manual
For
Digiquartz Broadband Intelligent Instruments with
Dual RS-232 and RS-485 Interfaces

SERIES 1000 / 6000 / 9000
INTELLIGENT PRESSURE TRANSMITTER

SERIES 8CDP / 8CB
INTELLIGENT DEPTH SENSOR

MODEL 715 DISPLAY

RS-232 / RS-485 SERIAL INTERFACE BOARD

“The standard by which other standards are measured”



OPERATION MANUAL
FOR
DIGIQUARTZ® BROADBAND
INTELLIGENT INSTRUMENTS WITH
DUAL RS-232 AND RS-485 INTERFACES

SERIES 1000 / 6000 / 9000
INTELLIGENT PRESSURE TRANSMITTER

SERIES 8CDP / 8CB
INTELLIGENT DEPTH SENSOR

MODEL 715 DISPLAY

RS-232 / RS-485 SERIAL INTERFACE BOARD

DOCUMENT NO. 8819-001
REVISION R
AUGUST 2010



WWW.PAROSCIENTIFIC.COM

COPYRIGHT 2010 PAROSCIENTIFIC, INC

TABLE OF CONTENTS

PAGE

1. Introduction	1-1
1.1. About this manual	1-1
1.2. Latest features	1-1
1.3. Conventions used in this manual	1-1
1.4. Safety precautions	1-2
1.5. Manual summary	1-3
2. Hardware Descriptions	2-1
2.1. Intelligent Transmitters (Series 1000 / 6000 / 9000)	2-1
2.2. Intelligent Depth Sensors (Series 8CDP, 8CB)	2-1
2.3. Model 715 Display	2-1
3. Installation	3-1
3.1. Pressure ports and buffer tubes	3-1
3.2. Oil filled vs. non-oil filled units	3-2
4. Universal Features and Functions	4-1
4.1. Measurement basics	4-1
4.2. Measurement descriptions	4-1
4.3. Measurement modes	4-2
4.4. Sampling types	4-3
4.5. Engineering units	4-4
4.6. Serial data output modes	4-4
4.7. Power management	4-4
4.8. Tare and overpressure	4-4
4.9. Measurement data formatting	4-5
4.10. RS-232 and RS-485 serial communications	4-6
4.11. Differences between the RS-232 and RS-485 ports	4-6
4.12. Calibration	4-6
4.13. Unit identification	4-7
4.14. Model 715 Display	4-7
5. Quick Start	5-1
6. Getting Started	6-1
6.1. Compatible serial hardware	6-1
6.2. Serial and power connections	6-1
6.3. Communications	6-1
6.4. Command basics	6-2
6.5. Command and response format	6-2
6.6. Digiquartz software programs	6-3
6.6.1. Digiquartz Interactive 2.0 (DQI 2.0)	6-3
6.6.2. Digiquartz Assistant (DQA)	6-4

7. Command Descriptions	7-1
7.1. Measurement commands	7-1
7.1.1. Single measurement commands	7-1
7.1.2. Sample and hold measurement commands	7-2
7.1.3. Continuous measurement commands	7-4
7.1.4. Minimum/Maximum pressure commands	7-6
7.1.5. Measurement integration time commands	7-7
7.1.6. Measurement mode commands	7-9
7.1.7. User-defined commands	7-11
7.2. Configuration commands	7-14
7.2.1. Enable write command	7-14
7.2.2. Communications commands	7-15
7.2.3. Engineering units commands	7-18
7.2.4. Power management commands	7-19
7.2.5. Tare and overpressure commands	7-20
7.2.6. Measurement data formatting commands	7-23
7.2.7. Unit identification commands	7-27
7.2.8. Time reference stamp command	7-29
7.2.9. Model 715 Display configuration commands	7-30
7.3. Serial data output mode command	7-34
7.4. Diagnostic commands	7-36
7.5. Calibration commands	7-36
7.6. Global commands	7-39
8. Nano-Resolution Features & Functions	8-1
8.1. Introduction	8-1
8.2. Enabling Nano-Resolution	8-2
8.3. Configuring IIR Filter Mode	8-2
8.4. Configuring FIR Filter Mode	8-4
8.5. Default Numeric Formats for IIR & FIR Modes	8-5
8.6. Controlling the Numeric Format	8-6
9. Resolution, Integration Time, and Sampling Rate	9-1
10. High-Speed Sampling	10-1
11. Networking Multiple Intelligent Devices	11-1
11.1. Networking basics	11-1
11.2. Choosing a networking type	11-1
11.3. RS-485 multi-drop networking	11-2
11.3.1. Characteristics unique to RS-485 multi-drop networking	11-3
11.3.2. 2-wire RS-485 multi-drop networking	11-4
11.3.3. 4-wire RS-485 multi-drop networking	11-4
11.4. RS-232 serial loop networking	11-5
11.5. Other networking methods	11-6

12. Using the Model 715 Display	12-1
12.1. Serial and power connections	12-1
12.2. Configuring an Intelligent device for use with the Model 715	12-1
12.3. Model 715 panel mounting instructions	12-2
13. I/O Lines	13-1
14. Connector Diagrams	14-1
14.1. Intelligent transmitters: 15-pin male high-density D-sub	14-1
14.2. Intelligent Depth Sensor connectors	14-2
14.2.1. Intelligent absolute depth sensors: Burton 5507-1508-000X	14-2
14.2.2. Intelligent gauge depth sensors: Burton 5999-0962-002	14-3
14.3. Model 715 connectors	14-4
14.3.1. Model 715 15-pin female high-density D-sub	14-4
14.3.2. Model 715: 9-pin female D-sub	14-5
14.4. Power Adapter Module connectors	14-6
14.4.1. Power Module 15-pin female high-density D-sub	14-6
14.4.2. Power Module 9-pin female D-sub	14-7
14.5. PC RS-232 port: 9-pin male D-sub connector	14-8
15. Serial Wiring Diagrams	15-1
15.1. RS-232 wiring diagrams	15-1
15.2. RS-232 serial loop network wiring diagram	15-2
15.3. RS-485 wiring diagrams	15-3
15.4. RS-485 multi-drop network wiring diagrams	15-4
15.5. Model 715 Display wiring diagrams	15-5
16. Troubleshooting	16-1
17. Internal Calculations and Formulas	17-1
18. Zero and Span Adjustments	18-1
19. Command and Parameter Reference	19-1

1. Introduction

1.1. About this manual

Thank you for your recent DIGIQUARTZ® Intelligent Transmitter or Depth Sensor purchase. This manual describes the operation of the entire line of Paroscientific DIGIQUARTZ Intelligent Transmitters and Depth Sensors equipped with dual RS-232 and RS-485 serial interfaces. DIGIQUARTZ Intelligent devices that support RS-232 only are covered by a separate manual, Paroscientific Document Number 8107-001.

1.2. Latest features

Starting with firmware revision R5.10 or later, it is now possible to achieve parts-per-billion resolution (nano-resolution) as opposed to parts-per-million resolution in standard mode. This feature can be easily enabled/disabled via software commands. Please refer to Section 8 for additional information on this new feature.

In addition, hardware shipping with firmware R4.10 or later includes a time reference stamp that will correlate data entries to the date/time they were taken. See Section 7.2.8 for further details.

1.3. Conventions used in this manual

The following conventions are used throughout this manual:

DIGIQUARTZ Intelligent Device – Any Series 1000, 6000, or 9000 Intelligent Transmitter, or Series 8000 Intelligent Depth Sensor with dual RS-232 and RS-485 ports.

DIGIQUARTZ Intelligent Transmitter – Any model from the Series 1000, 6000, or 9000 product lines with dual RS-232 and RS-485 ports.

DIGIQUARTZ Intelligent Depth Sensor – Any model from the Series 8000 product line with dual RS-232 and RS-485 ports.

CAUTION is used to draw your attention to a situation that may result in an undesirable outcome, but will not damage an Intelligent device.

WARNING is used to draw your attention to a situation that may result in permanent damage to an Intelligent device.

1.4. Safety precautions

DIGIQUARTZ Pressure Transmitters and Depth Sensors are precision devices, and as such, they should be operated with a certain degree of care to ensure optimum performance.

WARNING It is recommended that the input pressure not exceed 1.2 times the rated full-scale pressure. Calibration can be affected if this limit is exceeded, and permanent damage can result if the unit is sufficiently over-pressured.

WARNING Excessive mechanical shock may cause irreparable damage. Do not drop an Intelligent device, or allow tools to fall on the unit or its pressure port.

1.5. *Manual summary*

This manual is organized as follows:

Section 1	Introduction to this manual.
Section 2	Descriptions of the hardware covered in this manual.
Section 3	Information about installation.
Section 4	Description of the features and functions common to all DIGIQUARTZ Transmitters and Depth Sensors.
Section 5	Information needed to quickly connect a DIGIQUARTZ Intelligent device to a serial host and take pressure measurements.
Section 6	Information about interconnection, serial communications, command and response data format, measurement options, device configuration, and the DIGIQUARTZ application software.
Section 7	Detailed command descriptions.
Section 8	Description of the nano-resolution functionality.
Section 9	Explanation of the relationship between resolution, integration time, and sampling rate.
Section 10	Recommendations for maximizing sampling rate.
Section 11	Information regarding the operation of Intelligent devices in RS232 serial loop and RS485 multi-drop networks.
Section 12	Information about interconnecting and operating the Model 715 display with DIGIQUARTZ Intelligent devices.
Section 13	A functional description of the Tare Input, Tare Output, and Overpressure I/O lines.
Section 14	Connector pin-out diagrams for Intelligent devices, Model 715 Display, power adapter module, and PC RS-232 serial port.
Section 15	Wiring diagrams for simple RS232, simple RS485, RS232 serial loop network, and RS485 multi-drop network systems.
Section 16	Troubleshooting tips.
Section 17	Descriptions of the formulas used by DIGIQUARTZ Intelligent devices to calculate pressure and temperature.
Section 18	Information about zero and span calibration adjustments.
Section 19	A quick reference list of the commands supported by DIGIQUARTZ Intelligent devices.

2. Hardware Descriptions

2.1. Intelligent Transmitters (Series 1000 / 6000 / 9000)

DIGIQUARTZ Intelligent Transmitters consist of a pressure transducer and a serial interface board in an integral package. Commands are sent and measurement data are received via one RS-232 and one RS-485 serial port. Measurement data are provided directly in user-selectable engineering units with a typical total accuracy of 0.01% or better over a wide temperature range. Pressure measurements are fully temperature compensated using a precision quartz crystal temperature sensor. Each intelligent transmitter is preprogrammed with calibration coefficients for full plug-in interchangeability.

2.2. Intelligent Depth Sensors (Series 8CDP, 8CB)

DIGIQUARTZ Intelligent Depth Sensors consist of a pressure transducer and a serial interface board in a rugged waterproof package. Commands are sent and measurement data are received via one RS-232 and one RS-485 serial port. Measurement data are provided directly in user-selectable engineering units with a typical total accuracy of 0.01% or better over a wide temperature range. Pressure measurements are fully temperature compensated using a precision quartz crystal temperature sensor. Each intelligent depth sensor is preprogrammed with calibration coefficients for full plug-in interchangeability.

2.3. Model 715 Display

The Model 715 is an LCD display unit that can be used with DIGIQUARTZ Intelligent devices that are equipped with dual RS-232 and RS-485 serial interfaces. It features a two-line, 16 character alphanumeric LCD display that is backlit to ensure readability even in low light conditions. The Model 715 can communicate with a DIGIQUARTZ Intelligent device via either RS-232 or RS-485.

The Model 715 is housed in a sturdy metal enclosure that conforms to DIN specifications. It is designed for easy panel mounting, but can also function as a tabletop instrument when used with the optional bench stand.

3. Installation

DIGIQUARTZ Intelligent Transmitters can generally be mounted in any orientation. Mounting hole patterns for units so equipped can be found on the Specification Control Drawing (SCD) supplied with the unit.

CAUTION Pressure head effects vary with transmitter orientation, and result in zero offsets. These effects are more pronounced when liquid-filled pressure lines are being used. These effects can be minimized by keeping the transmitter pressure port and the pressure source at the same elevation, or by making an offset correction to compensate for the pressure head.

3.1. *Pressure ports and buffer tubes*

DIGIQUARTZ Intelligent Transmitters typically include a nylon or stainless steel buffer tube. The buffer tube is an integral part of the mechanical shock protection system of the transmitter.

Parker A-Lok or equivalent nut and ferrule fittings are used on most Digiquartz Intelligent Transmitters. The Series 1000 devices use the 1/8" OD configuration.

Two 7/16" wrenches are required when making or breaking any 1/8-inch pressure fitting. The first wrench is used to stabilize the stationary fitting, and the second wrench is used to turn the other fitting.

The Series 9000 transmitters use a 1/4" Modified HIP or equivalent fitting. A 5/8" wrench and 3/4" wrench are required to make and break these connections.

CAUTION It is recommended that pressure fittings are installed finger tight, then tightened an additional 3/4 turn to complete the pressure seal.

WARNING Avoid making connections directly to the transmitter pressure fitting. Make connections to the buffer tube fitting wherever possible. If the transmitter pressure fitting becomes flared, stripped or damaged, it will be necessary to return the unit to Paroscientific for repairs.

WARNING Do not remove the buffer tube. It is an integral part of the mechanical shock protection system of the transmitter.

For additional information, see the application note "The Use and Handling of Buffer Tubes" at www.paroscientific.com.

3.2. Oil filled vs. non-oil filled units

OIL FILLED TRANSMITTERS

Transmitters that are to be used to measure liquid media pressures are oil filled at Paroscientific. Transmitters that are oil filled should never be used in gas media applications.

Oil-fill and bleed all pressure lines that are to be connected to an oil filled transmitter. The same oil used to fill the transmitter should be used to fill the pressure lines; consult the transmitter Specification Control Drawing for details.

CAUTION If your transmitter and buffer tube are oil filled, do not pull a vacuum or apply pressurized gas to the unit. Doing so could allow bubbles to form in the pressure lines and transmitter, which will adversely affect the accuracy of the unit.

CAUTION Pressure head effects result in zero offsets. These effects are more pronounced when liquid filled pressure lines are being used. These effects can be minimized by keeping the transmitter pressure port and the pressure source at the same elevation, or by making an offset correction to compensate for the pressure head.

NON-OIL FILLED TRANSMITTERS

Non-oil filled transmitters are intended for use in dry gas media applications, and should never be used in liquid media applications.

WARNING If your transmitter and buffer tube are not oil-filled, do not apply pressurized liquid media to the unit. Liquid may contaminate the unit, and may adversely affect the accuracy of the unit. It is not possible to completely remove most liquids from the transmitter once they have been introduced.

For additional information, see the application note “Oil Filled Transducers Accuracy, Performance, and Handling” at www.paroscientific.com.

4. Universal Features and Functions

The following features and capabilities are common to all DIGIQUARTZ Intelligent Transmitters and Depth Sensors with dual RS-232 and RS-485 ports, except as noted. For the added benefits of nano-resolution signal processing, please refer to Section 8.

4.1. *Measurement basics*

The outputs from DIGIQUARTZ pressure transducers are two square wave signals whose period is proportional to applied pressure and internal transducer temperature. The Intelligent electronics measures these signals using a technique similar to that of a common laboratory frequency counter. Like the frequency counter, a signal must be integrated, or sampled, for a specified period of time to measure its period. The time over which the signal is sampled determines the resolution of the measurement. Longer sampling times increase resolution, but result in a slower sampling rate.

DIGIQUARTZ Intelligent devices allow you to set the integration time between 0.001 and 270 seconds in 0.001 second increments. Pressure and temperature integration times can be set independently. Measurements can be continuously taken in the background, or can be initiated when a measurement command is received. You can use these features to configure the intelligent device according to the data acquisition and resolution requirements of your application. Refer to Section 0 for more information about integration time, resolution, and sampling rate.

4.2. *Measurement descriptions*

One or both of the transducer's pressure and temperature signals are sampled, or integrated, depending on the type of measurement requested.

PRESSURE MEASUREMENTS

Pressure measurements are by far the most common. Pressure measurements are fully temperature-compensated, and therefore require an internal temperature measurement.

When a pressure measurement is made, the following sequence occurs:

1. The temperature and pressure signal periods are measured simultaneously.
2. A temperature-compensated pressure value is calculated using the pressure period, temperature period, and the calibration coefficients.
3. The pressure value is output.

INTERNAL SENSOR TEMPERATURE MEASUREMENTS

Internal sensor temperature is normally only used for temperature compensation of pressure, but can be requested independently for diagnostic purposes.

When an internal sensor temperature measurement is made, the following sequence occurs:

1. The temperature signal period is measured
2. A temperature value is calculated using the temperature period and the calibration coefficients
3. The temperature value is output

PRESSURE AND TEMPERATURE PERIOD MEASUREMENTS

Period measurements are used mainly for calibration and diagnostic purposes, but may be useful in high-speed sampling applications.

When a period measurement is made, the following sequence occurs:

1. The pressure or temperature signal period is measured
2. The period value is output

Refer to Section 7.1 for detailed measurement command descriptions.

4.3. Measurement modes

TRIGGER MODE VS. FETCH MODE

In Trigger Mode, measurements are initiated when a measurement command is received. Data is output when the new measurement is complete. This is the mode in which DIGIQUARTZ intelligent devices have traditionally operated. In Fetch Mode, measurements are continuously taken in the background. When a measurement command is received, the most recently acquired measurement value is immediately output. Refer to Section 7.1.6 for more information.

SEQUENTIAL INTEGRATION VS. SIMULTANEOUS INTEGRATION

Until recently, DIGIQUARTZ intelligent devices used a Sequential Integration scheme for measuring the sensor's pressure and temperature signals. With Sequential Integration, the temperature period is integrated first, followed by the pressure period.

Recent advances in microprocessor technology have enabled DIGIQUARTZ transmitters and depth sensors to integrate the temperature and pressure signals simultaneously. Simultaneous Integration results in faster data acquisition without sacrificing measurement resolution. Simultaneous Integration is available in all DIGIQUARTZ transmitters and depth sensors with firmware version R4.00 and later. For backward compatibility with earlier units, a Sequential Integration

Simulation mode is also available. The Sequential Integration Simulation uses Simultaneous Integration but produces measurement timing similar to units with firmware versions prior to R4.00.

Figure 1 illustrates the differences between Sequential Integration, Simultaneous Integration, and Sequential Integration Simulation. Refer to Section 7.1.6 for more information about Sequential and Simultaneous Integration.

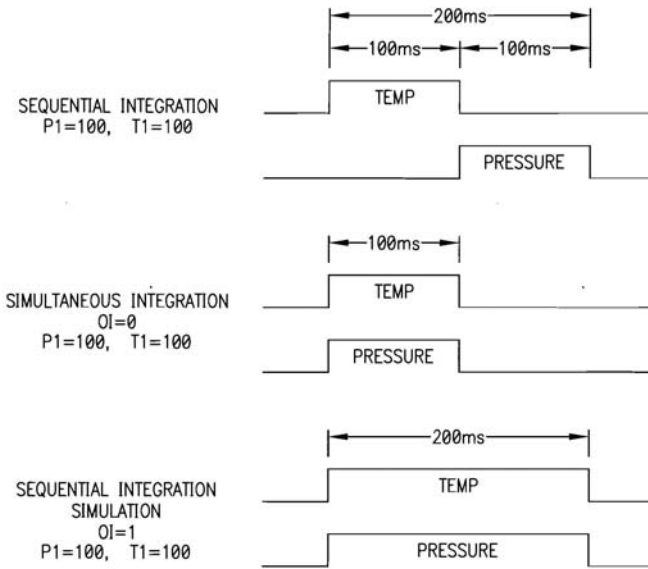

Figure 1: Timing Diagram – Simultaneous vs. Sequential Integration

4.4. Sampling types

SINGLE MEASUREMENT SAMPLING

Single measurement sampling commands output a single measurement value each time the command is received.

CONTINUOUS MEASUREMENT SAMPLING

Continuous measurement sampling commands repeatedly output measurement data until commanded to stop.

SAMPLE AND HOLD MEASUREMENT SAMPLING

Similar to single measurement sampling, but the measurement value is not output until a separate command is sent. This type of sampling is useful when you need to simultaneously trigger measurements from multiple units, and then read them one by one in a particular order.

Refer to Section 7.1 for detailed measurement command descriptions.

4.5. Engineering units

Pressure values can be expressed in the following engineering units. Refer to the **UN** command in Section 7.2.3 for details.

- psi
- hPa (mbar)
- bar
- kPa
- MPa
- in Hg
- mm Hg (Torr)
- m H₂O
- User-defined units

Temperature values can be expressed in the following units. Refer to the **TU** command in Section 7.2.3 for details.

- °C
- °F

4.6. Serial data output modes

In addition to the sampling types described in Section 4.3, DIGIQUARTZ Intelligent devices can also be configured to provide continuous pressure measurement data whenever power is applied. Refer to Section 7.3 for details.

4.7. Power management

You can configure a DIGIQUARTZ Intelligent device to automatically switch to a low power “sleep” state after a user-defined period of serial inactivity, thus conserving power. When serial activity resumes, the unit will “awaken”, allowing normal operation. Refer to Section 7.2.4 for details.

4.8. Tare and overpressure

You can configure the DIGIQUARTZ Intelligent device to subtract a value from each subsequent pressure measurement. This process is referred to as “taring.” You can tare to the current pressure value, or to any value you specify. Taring can be initiated by contact closure via a dedicated digital input line, or by serial command. A dedicated digital output and/or a special character in the measurement data can be used to indicate whether taring is in effect. Refer to Sections 7.2.5 and 13 for details.

You can configure the DIGIQUARTZ Intelligent device to indicate whether the measured pressure exceeds a user-specified setpoint. This indication is provided via a dedicated digital output line. Refer to Sections 7.2.5 and 13 for details.

NOTE: Tare and overpressure I/O lines are not available with DIGIQUARTZ Intelligent Depth Sensors.

4.9. Measurement data formatting

Several serial data formatting options have been provided, and are listed below. Refer to Section 7.2.6 for details.

- **User-Defined Commands:** Lets you create your own custom measurement commands, containing any combination of measurement values and text strings. See the **OF** and **OM** commands for details.
- **Engineering Unit Suffix:** Appends the engineering unit to pressure and temperature measurement data. See the **US** command for details
- **Underscore Separator:** Adds underscore(s) to pressure and temperature measurement data to separate the measurement value from the address header and optional engineering unit. See the **SU** command for details.
- **Tare Indicator:** Adds an uppercase ‘T’ character to pressure measurement data to indicate a tared value. See the **ZI** command for details.
- **Data Logger Format:** Converts measurement data to a predictable fixed-length and fixed-position format to simplify parsing by data loggers and other programmable serial hosts. See the **DL** command for details.
- **User-Defined Unit Label:** Lets you define the 4-character unit label to be used when the user-defined pressure unit is selected. See the **UM** command for details.

4.10. RS-232 and RS-485 serial communications

DIGIQUARTZ Intelligent devices are equipped with both RS-232 and RS-485 serial ports. Commands can be sent to either port. Response data, if any, will be output from the port that received the command. Common baud rates between 300 and 115,200 baud are supported. The serial protocol is fixed at 8 data bits, no parity, and 1 stop bit.

Up to 98 units and an RS-232 serial host can be interconnected to form a serial loop network. Refer to Sections 7.2.2, 11.4, and 15 for details. Additionally, up to 98 units and an RS-485 serial host can be interconnected to form a 2-wire or 4-wire RS-485 multi-drop network. Refer to Sections 7.2.2, 11.3, and 15 for details.

You communicate with a specific DIGIQUARTZ Intelligent device by sending commands to its ID number. You can also send certain commands to all devices on a network by sending the command to the global address. Refer to Sections 6.3, 6.4, and 7.6 for details.

4.11. Differences between the RS-232 and RS-485 ports

Generally, DIGIQUARTZ Intelligent devices respond identically to commands received on either port, with the following exceptions:

- Global commands received by the RS-232 port are re-transmitted. This enables a global command to be relayed to each device in an RS-232 serial loop network. Refer to Section 11.4 for more information about RS-232 serial loop networking.
- Commands received by the RS-232 port that are addressed for other devices are re-transmitted. This behavior is necessary to support RS-232 serial loop networking. Refer to Section 11.4 for more information about RS-232 serial loop networking.
- Global commands received by the RS-485 port never generate a response. This prevents the data collision that would occur if all devices on a multi-drop network were to respond simultaneously. Refer to Section 11.3 for details.

4.12. Calibration

DIGIQUARTZ Intelligent devices are shipped fully calibrated. Calibration data are shipped with the unit in printed form, and are stored within the device in non-volatile memory. These values should not be modified unless it is absolutely necessary to do so, and then only with extreme caution. See Section 7.5 for details.

4.13. Unit identification

DIGIQUARTZ Intelligent devices are shipped with several unit identification values stored in non-volatile memory. These read-only values include:

- Serial and model numbers
- Full-scale pressure
- Transducer type.

Refer to Section 7.2.7 for details.

4.14. Model 715 Display

DIGIQUARTZ Intelligent devices can be used with the Model 715 Display to display pressure, temperature, and user-defined alphanumeric information. The Model 715 can communicate with DIGIQUARTZ Intelligent devices via either RS-232 or RS-485. User-defined alphanumeric display information can be stored in the DIGIQUARTZ Intelligent device, or can be sent directly from the serial host to the Model 715 display. Intelligent devices support several commands that control the Model 715 display. Refer to Section 7.2.8 for details.

DIGIQUARTZ Intelligent devices with dual RS-232 and RS-485 ports are not compatible with the Model 710 display. Older Intelligent devices with RS-232 only are not compatible with the Model 715 display.

5. Quick Start

This section will help you to quickly connect your DIGIQUARTZ Intelligent device to the RS-232 serial port of a standard PC, establish communications, and take your first pressure measurements.

This process will be much simpler and easier if you have purchased the RS232/RS485 Power Module Kit (110V p/n 1294-001, 220V p/n 1294-002. The kit includes the following items:

- Power adapter module, p/n 6671-003
- 110 or 220 VAC wall power supply, p/n 6024-001 or 6024-002
- 9-pin serial cable, p/n 6409-003

Step 1. Connect up the system

If you have the Power Module Kit:

- Connect up the system as shown in Figure 13 in Section 15.
- Plug in the wall power supply.

If you don't have the Power Module Kit:

- Connect up the system as shown in Figure 14 in Section 15.

Step 2. Run Digiquartz Interactive 2.0 (DQI)

- Install Digiquartz Interactive 2.0 on your PC. Digiquartz Interactive 2.0 can be installed from the Digiquartz CD Library that was included with your instrument.
- Connect the RS-232 port of your instrument to the RS-232 port of your PC, and power up the instrument.
- Run Digiquartz Interactive 2.0.
- Select the Configuration and Monitoring option, and click Next.
- Set the Search Type to RS-232/USB. If the RS-232 COM port number is known, set COM Port to that value; if the COM port number is unknown, set COM Port to All. Set Baud Rate to All.
- Click Begin Search. DQI will attempt to detect the MET4/MET4A, and if successful, will display its serial number and communications parameters. **NOTE:** If the search ends and your instrument is not located, close DQI 2.0, and ensure that your instrument is powered and properly connected to the PC RS-232 port before running DQI 2.0 again.
- When your instrument is located, click Next to continue.
- Click the Numerical Display Tab.

- Select your instrument from the Instrument List, and click Start. Pressure (and diagnostic measurement values, if selected) will be displayed and periodically updated.

Congratulations! You have taken your first pressure measurement! We encourage you to use DQI 2.0 to explore the remaining functions of your DIGIQUARTZ Intelligent device. Refer to the Help function in DQI 2.0 for more information.

6. Getting Started

6.1. Compatible serial hardware

DIGIQUARTZ Intelligent devices are compatible with any equipment that conforms to the EIA RS-232 and/or RS-485 specifications. They are also backward compatible with earlier Intelligent devices that support RS-232 only, and can be used together in RS-232 serial loop networks.

DIGIQUARTZ Intelligent devices with dual RS-232 and RS-485 ports are not compatible with the Model 710 display, and DIGIQUARTZ Intelligent devices with RS-232 only are not compatible with the Model 715 display.

6.2. Serial and power connections

Serial and power connections are made via a male 15-pin high-density D-subminiature connector. Refer to Section 14 for connector pin details.

Refer to section 15 for detailed system wiring diagrams.

It is recommended that you establish communications and verify transmitter operation prior to permanently installing the device. The RS232/RS485 Power Module Kit (110V p/n 1294-001, 220V p/n 1294-002) simplifies the task of powering the transmitter and making RS-232 serial connections to a PC or other serial host.

NOTE: The RS232/RS485 Power Module Kit is intended for use with DIGIQUARTZ Intelligent transmitters, and is not compatible with Intelligent depth sensor products.

6.3. Communications

DIGIQUARTZ Intelligent devices are initially configured for RS232/RS485 communications at 9,600 baud. The serial protocol is fixed at 8 data bits, no parity, and 1 stop bit. Each Intelligent device has an ID number, and will only respond to commands sent to its ID number or 99. ID number 99 is reserved as a global address, which can be used to send a single command to multiple devices at once. The ID number is initially configured to 01, but you can set the ID number to any value between 01 and 98.

It is recommended that DIGIQUARTZ Interactive 2.0 (DQI 2.0) software be used to establish initial communications with your transmitter. Refer to the DIGIQUARTZ CD library and Section 6.6 for details.

You may also use any terminal program that is configured for the proper baud rate and serial protocol. Your terminal program must also send a line-feed character (ASCII 10) with each carriage return.

6.4. *Command basics*

DIGIQUARTZ Intelligent devices are controlled by serial ASCII command strings. The following basic tasks can be accomplished by sending the appropriate command:

- Take a measurement
- Perform a control function, such as locking the baud rate
- Set an operating parameter, such as integration time
- Read the value of an operating parameter

When setting virtually all parameter values, you must precede the command with an **EW** command. This prevents accidental alteration of stored parameter values. Please refer to Section 7.2.1 for more information about the **EW** command.

Measurement commands typically generate a response that contains the measurement data. Parameter set commands typically generate a response that reports the updated parameter value. Parameter read commands report the current parameter value.

6.5. *Command and response format*

Commands are typically sent in the following form: *0100P3CrLf

Where:	* = start character	(ASCII 42)
	01 = Destination ID	(ID of intelligent device that is to respond to the command)
	00 = Source ID	(Serial host is ID 00)
	P3 = Command	P3 is an example. Refer to Section 7 for descriptions of the entire command set.
	Cr = Carriage return	(ASCII 13)
	Lf = Linefeed character	(ASCII 10)

Responses are typically received in the following form: *000114.4567CrLf

Where:	* = start character	(ASCII 42)
	00 = Destination ID	(ID of serial host)
	01 = Source ID	(ID of device that is responding)
	14.4567 = Data	(Data sent in response to a measurement command)
	Cr = Carriage return	(ASCII 13)
	Lf = Linefeed character	(ASCII 10)

These examples are typical. Refer to Section 7 for specific details regarding each supported command.

6.6. Digiquartz software programs

Paroscientific provides software programs that simplify common measurement and configuration tasks. These programs can be found on the DIGIQUARTZ CD Library, which is provided with each Intelligent device purchase. The latest versions of these and other software programs are also available at the Paroscientific web site, at www.paroscientific.com.

6.6.1. Digiquartz Interactive 2.0 (DQI 2.0)

Digiquartz® Interactive 2.0 is a Windows program that makes it easy to communicate with and configure DIGIQUARTZ Intelligent devices. We encourage you to install DQI 2.0 and use it to verify proper device operation, configure your device, take measurements, and experiment with its functions.

DQI 2.0 is separated into two main sections: Configuration and Monitoring, and Digiquartz Terminal.

The Configuration and Monitoring section provides a means of viewing, changing, storing, and retrieving the configuration parameters of your instrument. It also allows you to take measurements and display them numerically and in a real-time graph. Measurement data may also be logged to a text file in a format that can be easily imported into popular PC programs such as Microsoft Excel® or Word®.

The Digiquartz Terminal section allows you to interactively communicate with your instrument using text-based commands. Measurement data may be logged to a text file in a format that can be easily imported into popular PC programs such as Microsoft Excel® or Word®.

6.6.2. Digiquartz Assistant (DQA)

DIGIQUARTZ Assistant is a Windows data logging program. With DQA, you can log time-stamped measurement data from up to 8 DIGIQUARTZ Intelligent devices. Measurement data can also be displayed in real time in an automatically scaled graph. Data is stored to a text file in a format that can easily be imported into popular PC programs such as Microsoft Word or Excel. Refer to the help function in DQA for more information.

7. Command Descriptions

7.1. Measurement commands

The following commands are used to initiate measurements, control measurement integration times, set measurement modes, and work with user-defined commands. For additional commands associated with nano-resolution signal processing, please refer to Section 8.

7.1.1. Single measurement commands

The following commands are used to initiate single measurements. They return the resulting measurement value as soon as it is available when in Trigger Mode, or immediately if in Fetch Mode. Refer to Section 7.1.6 for more information about Trigger Mode and Fetch Mode.

- P1** Sample and send one pressure period measurement in microseconds.
Action: Measure pressure period, send pressure period value, and await next command.
Typical command: *0100P1
Typical response: *000128.123456 (Value: 28.123456)
- P3** Sample and send one pressure measurement in selected engineering units.
Action: Measure temperature period, measure pressure period, calculate temperature-compensated pressure, send pressure value, and await next command.
Typical command: *0100P3
Typical response: *000114.71234 (Value: 14.71234)
- Q1** Sample and send one temperature period measurement in microseconds).
Action: Measure temperature period, send temperature period value, and await next command.
Typical command: *0100Q1
Typical response: *00015.1234567 (Value: 5.1234567)

- Q3** Sample and send one temperature measurement in selected engineering units.
Action: Measure temperature period, calculate temperature, send temperature value, and await next command.
Typical command: *0100Q3
Typical response: *000122.345 (Value: 22.34)

7.1.2. Sample and hold measurement commands

The following commands are used to initiate and send single sample and hold measurements. Measurement values are held until the next command is received. If the next command is a **DB** or **DS** command, the measurement value is sent; if it is any other command, the measurement value is lost. If a **DB** or **DS** command is received before the measurement command is complete, the measurement value will be sent as soon as it is available.

NOTE: Fetch Mode does not affect sample and hold measurement commands. Refer to Section 7.1.6 for more information about Fetch Mode.

- P5** Sample and hold one pressure measurement in selected engineering units.
Action: Measure temperature period, measure pressure period, calculate temperature-compensated pressure, save pressure value, and await DB command.
Typical command: *0100P5
Typical response: No response until DB command is received
- P6** Sample and hold one pressure period measurement in microseconds.
Action: Measure pressure period, save pressure period value, and await DB command.
Typical command: *0100P6
Typical response: No response until DB command is received
- Q5** Sample and hold one temperature measurement in selected engineering units.
Action: Measure temperature period, calculate temperature, save temperature value, and await DB command.
Typical command: *0100Q5
Typical response: No response until DB command is received

Q6 Sample and hold one temperature period measurement in microseconds.
Action: Measure temperature period, save temperature period value, and await DB command.

Typical command: *0100Q6

Typical response: No response until DB command is received

DB Dump Buffer. Send held measurement values.

Action: If a measurement value is being held, send it, otherwise do nothing.

Typical command: *0100DB

Typical response: *000114.12345 (Value: 14.12345)

DS Dump Sequential. Send held measurement values.

Action: Similar to **DB** command except it guarantees that the responses are received in sequential order from multiple transducers on an RS-232 serial loop network.

Typical Command: * 9900DS

Typical response: * 000114.576 First transmitter
* 000214.577 Second transmitter
* 9900DS

NOTE: **DS** is available in firmware version R3.00 and later.

NOTE: **DS** is only useful in RS-232 serial loop applications. Do not use **DS** in RS-485 applications.

NOTE: **DS** returns measurement command responses in sequential order according to the location of the devices on an RS-232 serial loop.

7.1.3. Continuous measurement commands

The following commands are used to initiate and control continuous measurements. Continuous measurement commands repeatedly take measurement samples and return measurement values until commanded to stop or power is lost. Continuous measurement commands are cancelled when any valid command is received, and do not resume when power is cycled.

NOTE: Fetch Mode does not affect continuous measurement commands. Refer to Section 7.1.6 for more information about Fetch Mode.

P2 Continuously sample and send pressure period measurement values in microseconds.
Action: Measure pressure period, send pressure period value, and repeat until commanded to stop.

Typical command: *0100P2
Typical response: *000128.123456 (Value: 28.123456)
*000128.123457 (Value: 28.123457)
*000128.123456 ... (Value: 28.123456)

P4 Continuously sample and send pressure measurement values in selected engineering units.
Action: Measure temperature period, measure pressure period, calculate temperature-compensated pressure, send pressure value, and repeat until commanded to stop.

Typical command: *0100P4
Typical response: *000114.71234 (Value: 14.71234)
*000114.71235 (Value: 14.71235)
*000114.71234 ... (Value: 14.71234)

NOTE: **P4** and **P7** function identically when **OI=0**.

P7 High-speed continuous pressure measurement in selected engineering units.

Action: Continuously sample and send pressure measurement values, using temperature measurement interval specified by the current value of **PS**. **P7** automatically performs the following sequence:

1. Initially measure temperature period.
2. Measure pressure period.
3. Calculate temperature-compensated pressure using last temperature period measurement.
4. Send pressure value.
5. Do steps 2-4 the number of times specified by **PS**, then measure temperature period.
6. Repeat steps 2-5 until commanded to stop.

Typical command: *0100P7

Typical response: *000114.71234 (Value: 14.71234)

*000114.71235 (Value: 14.71235)

*000114.71234 ... (Value: 14.71234)

NOTE: **P7** allows you to maximize the pressure sampling rate by taking temperature measurements at the interval specified by the **PS** command. Each subsequent pressure value is temperature-compensated using the currently stored temperature value. You can take a single initial temperature measurement, or you can take periodic temperature measurements at the interval you select with the **PS** command. Please refer to the **PS** command for more information.

NOTE: **P7** and **P4** function identically when **OI**=0.

PS Set or read the temperature measurement interval used by the **P7** command.

Action: Controls how often temperature measurements are taken during a **P7** pressure measurement sequence.

If **PS**=0, an initial temperature measurement is taken, and all subsequent pressure measurements are compensated using that value.

If **PS**=1, a temperature measurement is taken before each pressure measurement (same as **P4**).

If **PS**=n and n>1, an initial temperature measurement is taken, and subsequent temperature measurements are taken after every n pressure measurements.

Range: 1 to 65535

Typical command: *0100EW*0100PS=4

Typical response: *0001PS=4

NOTE: When setting virtually all parameter values, you must precede the command with an **EW** (**Enable Write**) command. Please refer to Section 7.2.1 for more information.

Q2 Continuously sample and send temperature period measurement values in microseconds.

Action: Measure temperature period, send temperature period value, and repeat until commanded to stop.

Typical command: *0100Q2

Typical response: *00015.1234567 (Value: 5.1234567)

*00015.1234568 (Value: 5.1234568)

*00015.1234567 ... (Value: 5.1234567)

Q4 Continuously sample and send temperature measurement values in selected engineering units.

Action: Measure temperature period, calculate temperature, send temperature value, and repeat until commanded to stop.

Typical command: *0100Q4

Typical response: *000122.345 (Value: 22.345)

*000122.346 (Value: 22.346)

*000122.345 ... (Value: 22.345)

7.1.4. Minimum/Maximum pressure commands

DIGIQUARTZ Intelligent devices support commands that return the minimum and maximum pressure measurement values taken since the most recent reset event.

The minimum and maximum pressure values will be reset to the next pressure measurement value when the **MR** command is received, coefficients or PA/PM are changed, taring is enabled or disabled, or power is cycled. After being reset, the minimum and maximum pressure values are not valid until a pressure measurement has been made.

- M1** Read the minimum pressure measurement values taken since the most recent reset event. **M1** is a read-only command.
Units: Current pressure unit set by **UN** command
Typical read command: *0100M1
Typical read response: *0001M1=14.12345
NOTE: The minimum pressure value will be scaled to the new pressure unit if the value of **UN** is changed.
- M3** Read the maximum pressure measurement values taken since the most recent reset event. **M3** is a read-only command.
Units: Current pressure unit set by **UN** command
Typical read command: *0100M3
Typical read response: *0001M3=14.12345
NOTE: The maximum pressure value will be scaled to the new pressure unit if the value of **UN** is changed.
- MR** Reset the minimum and maximum pressure values.
Action: Resets the minimum and maximum pressure to the next pressure measurement value.
Typical command: *0100MR
Typical response: *0001MR>OK
NOTE: The minimum and maximum pressure values are also reset when power is cycled.

7.1.5. Measurement integration time commands

DIGIQUARTZ Intelligent devices sample the transducer's pressure and temperature signals for a length of time specified by the measurement integration time commands. The measurement integration time has a direct affect on sampling rate and measurement resolution. See Section 9 for details.

PI and **TI** are the primary integration time commands for pressure and temperature signal measurement. The legacy commands **PR** and **TR** may also be used. The advantage of **PI** and **TI** is that the specified integration time is expressed directly in milliseconds.

NOTE: The legacy commands **PR** and **TR** traditionally specified the number of signal periods to sample. This integration scheme has been replaced by integration over a fixed length of time. For backward compatibility, values input using **PR** and

TR are converted to an equivalent time using nominal pressure and temperature period values.

NOTE: When Simultaneous Integration is selected, the pressure and temperature signals are integrated simultaneously, resulting in faster data rates at a given pressure resolution. In this case, the time needed to acquire a pressure measurement is controlled by the greater of the pressure and temperature integration times. See Sections 4.3 and 7.1.6 for more information about Simultaneous Integration.

Primary integration time commands

PI Set or read the pressure measurement integration time

Units: Milliseconds

Range: 1 to 290000 (.001 to 290 seconds), integer values only

Default: 666

Typical set command: *0100EW*0100PI=1000

Typical set response: *0001PI=1000

Typical read command: *0100PI

Typical read response: *0001PI=1000

NOTE: Whenever the value of **PI** is changed, **TI** is automatically updated with the same value.

TI Set or read the temperature measurement integration time

Units: Milliseconds

Range: 1 to 290000 (.001 to 290 seconds), integer values only

Default: 666

Typical set command: *0100EW*0100TI=1000

Typical set response: *0001TI=1000

Typical read command: *0100TI

Typical read response: *0001TI=1000

NOTE: Changing **TI** has no effect on **PI**.

NOTE: It is usually recommended that **TI** and **PI** be set to the same value.

NOTE: Do not set **PI** to a value of less than 10 when using a Model 715 display. Doing so may result in an inconsistent display.

Legacy integration time commands

PR Set or read pressure measurement integration time

Units: None

Range: 1 to 16383, integer values only

Default: 238

Typical set command: *0100EW*0100PR=200

Typical set response: *0001PR=200

Typical read command: *0100PR

Typical read response: *0001PR=200

NOTE: Whenever the value of **PR** is changed, **TR** is automatically updated with the value of **PR** times 4.

NOTE: Whenever the value of **PR** is changed, **PI** is automatically updated to reflect the equivalent pressure integration time.

TR Set or read temperature measurement integration time

Units: None

Range: 1 to 65535, integer values only

Default: 952

Typical set command: *0100EW*0100TR=800

Typical set response: *0001TR=800

Typical read command: *0100TR

Typical read response: *0001TR=800

NOTE: Changing **TR** has no effect on **PR**.

NOTE: Whenever the value of **TR** is changed, **TI** is automatically updated to reflect the equivalent temperature integration time.

7.1.6. Measurement mode commands

OI Select Simultaneous Integration or Sequential Integration Simulation

Action: The OI command is used to select Simultaneous Integration or Sequential Integration Simulation. When Simultaneous Integration is selected, the pressure and temperature periods are integrated simultaneously, resulting in increased data rates

without sacrificing measurement resolution. When Sequential Integration Simulation is selected, the pressure and temperature periods are still integrated simultaneously, but the measurement timing is similar to units that only support Sequential Integration (firmware versions prior to R4.00).

Values: 0 = Simultaneous Integration
1 = Sequential Integration Simulation

Default: 1

Typical set command: *0100EW*0100OI=1

Typical set response: *0001OI=1

Typical read command: *0100OI

Typical read response: *0001OI=1

NOTE: When Simultaneous Integration is selected, the total integration time is equal to either the pressure (**PI**) or temperature (**TI**) integration time, whichever is greater.

When Sequential Integration Simulation is selected, the total integration time is equal to the sum of the pressure (**PI**) and temperature (**TI**) integration times.

Refer to Section 4.3 for more information about Simultaneous Integration, Sequential Integration, and Sequential Integration Simulation.

FM Set or read Fetch Mode enable

Action: The FM command is used to select Trigger Mode or Fetch Mode. When in Trigger Mode, the unit initiates a new measurement when the measurement command is received. This is the mode in which DIGIQUARTZ Intelligent devices have traditionally operated. In Fetch Mode, measurement data is continuously acquired in the background, and the unit responds immediately to measurement commands with the most recent measurement value.

Values: 0 = Unit operates in Trigger Mode.
1 = Unit operates in Fetch Mode.

Default: 0

Typical set command: *0100EW*0100FM=1

Typical set response: *0001FM=1

Typical read command: *0100FM

Typical read response: *0001FM=1

NOTE: When in Fetch Mode, it is not possible for the unit to enter Sleep Mode. See the **SL** command for details.

7.1.7. User-defined commands

The user-defined commands enable you to define custom commands. All measurement options are available. Any combination of measurements and text can be specified, and measurement values can be formatted per your specifications.

User-defined commands consist of an output mask command to define the command behavior, and an associated command to execute the output mask. Three independent user-defined commands are available.

To use a user-defined command, the output mask must be defined using the OM command. The output mask typically contains some combination of command codes, text strings, and numeric format specifiers, each separated by a comma. The OF command is used to execute the command defined by OM.

COMMAND CODES

Command codes are used in the output mask to produce measurement or text output when executed. The available command codes are listed in Table 1 below.

Table 1: Command Codes for User-Defined Commands

Command Code	Description	Format Specifier?
P	Pressure	Y
MINP	Minimum pressure	Y
MAXP	Maximum pressure	Y
ST	Sensor temperature	Y
PPER	Pressure period	Y
TPER	Temperature period	Y
TV	Tare value	N
PU	Pressure unit	N
TU	Sensor temperature unit	N
UA	Destination ID	N
HA	Source ID	N
CR	Carriage return	N
LF	Line feed	N
CRLF	Carriage return/line feed	N
STAR or S	Asterisk	N
RESET	Set mask to default – must be used alone	N
HEAD or H	Same as STAR, HA, UA	N
END or E	Same as CR,LF	N
SPACE or SP	Space character	N

NOTE: Command codes can be upper or lower case.

NOTE: To work with a serial loop network, the output mask must begin with a STAR command code, and the second and third characters of the resulting response data must not match the address of any intelligent devices on the serial loop network.

TEXT STRINGS

Text strings are literal text delimited by quote characters. They can be inserted at any location with the output mask. The most common use of text strings is to annotate measurement values.

Example: “This is my text” will output “This is my text” (less the quote characters) when executed.

NUMERIC FORMAT SPECIFIERS

Numeric format specifiers are used to control the format of measurement values. The command codes that can be used with numeric format specifiers are identified as such in Table 1. Numeric format specifiers are placed immediately after the command code to which they apply.

Numeric format specifiers have the syntax x.y, where x and y are any number between 0 and 9.

The x value specifies the number of digits to the left of the decimal point that will be output. All digits to the left of the decimal point are always output regardless of the x value. If the x value is greater than the number of digits to the left of the decimal point, the output will be padded with leading zeros.

The y value specifies the number of digits to the right of the decimal point that will be output. If the y value is less than the number of digits to the right of the decimal point, the output will be rounded to the number of digits specified. If the y value is greater than the number of digits to the right of the decimal point, the output will be padded with trailing zeros.

Refer to Table 2 for examples.

Table 2: User-defined Numeric Formatting Examples

Output Mask	Value	Output
P1.5	14.56789	14.56789
MINP5.5	14.56789	00014.56789
MAXP2.2	14.56789	14.57
P2.7	14.56789	14.5678900
P5.7	14.56789	00014.5678900

COMMANDS

OM Set or read the user-defined command output mask. Three output masks can be defined - **OM1**, **OM2**, and **OM3**. The number is optional - if no number is specified, **OM1** is assumed.

Range: 200 characters maximum.

Default: OM1 - STAR,HA,UA,P,CRLF

OM2 - STAR,HA,UA" ",P," ",PU,CRLF

OM3 - STAR,Pressure:" ,P," ",PU,"; P Period:" ,PPER,";

Temp:" ,ST," ",TU,"; T Period:" ,TPER,CRLF

Typical set command: *0100EW*0100OM="Pressure:" ,P,CRLF

Typical set response: *0001OM="Pressure:" ,P,CRLF

Typical read command: *0100OM

Typical read response: *0001OM="Pressure:" ,P,CRLF

If a syntax error is detected, an error code is returned, along with the output mask up to the point where the error was detected. The syntax error will be between the last comma and the end of the returned output mask. Refer to Table 3 for the list of **OM** error codes and descriptions.

Table 3: OM Command Error Codes

OM Error Code	Description
O1	Unrecognized command
O2	Missing quote character
O3	Output mask too long
O4	RESET mixed with other command codes
O5	Bad format specifier

OF Executes the associated user-defined command output mask. **OF1**, **OF2**, and **OF3** execute output masks defined by **OM1**, **OM2**, and **OM3**, respectively. The number is optional - if no number is specified, **OF1** is assumed. Adding an R to the end of the command (example: **OF1R**) causes the command to execute continuously until another command is received or power is lost.

Typical command: *0100OF

Typical response: Pressure: 14.12345

The **OF** command processes command codes in the order that they appear in the output mask. The output for each code is sent as it is processed.

EXAMPLES

The following examples illustrate various output mask possibilities and the resulting serial responses:

Table 4: Single Response, OM / OF Examples

OM Output Mask	OF Command Result
OM = STAR,HA,UA,P," psi"	*000114.5678 psi
OM = HEAD,P,END	*000114.5678<CRLF>
OM = HEAD,P2.2,END	*000114.57<CRLF>
OM = "Min: ",MINP,SPACE, "Max: ",MAXP	Min: 14.5678 Max: 14.5687

Table 5: Continuous Response, OM / OFR Examples

OM Output Mask	OFR Command Result
OM = STAR,HA,UA,P," psi",CRLF	*000114.5678 psi<CRLF> *000114.5678 psi<CRLF> *000114.5678 psi<CRLF>...

7.2. Configuration commands

7.2.1. Enable write command

When setting virtually all parameter values, you must precede the parameter set command with an **EW** (Enable Write) command. Parameter set commands will be ignored unless they are preceded with an **EW** command.

EW Enables the next parameter set command to write a new value into non-volatile memory. You can issue **EW** as a separate command by terminating it with a carriage return/line feed, or you can string the **EW** and parameter set commands together, as shown below.

Typical syntax: *0100EW *0100TR=800
Alternate syntax: *0100EW
 *0100TR=800

7.2.2. Communications commands

The following commands are used to configure DIGIQUARTZ Intelligent devices for serial communications.

BR Set the RS-232 and RS-485 baud rate. Each individual port can be independently set to its own baud rate.

Action: The **BR** command is used to set the baud rate of the RS-232 and RS-485 ports. The BR command must be addressed to 99, the global ID. This ensures that all units on a network are set to the same baud rate. It is not possible to read the baud rate value.

There are three options for the **BR** command. **BR** sets the baud rate of both ports. **BR1** sets the baud rate of the RS-232 port only, and does not affect the RS-485 port. **BR2** sets the baud rate of the RS-485 port only, and does not affect the RS-232 port.

The **BR** command is unique in that it does not need to be preceded by an EW command.

Values: 300, 600, 1200, 4800, 9600, 19200, 38400, 57600, and 115200

Default: 9600

Typical set command: *9900BR=19200 (both ports set to 19200)

Alternate set command: *9900BR1=19200 (RS-232 port set to 19200)

Alternate set command: *9900BR2=19200 (RS-485 port set to 19200)

Typical set response: *9900BR=19200

CAUTION Be careful to only set the baud rate to a value supported by your serial host! If you accidentally set the baud rate to an unsupported value and subsequently lose serial communications, use a PC and the DIGIQUARTZ Terminal program to establish communications and restore the baud rate to a supported value.

BL Set or read the Baud Lock parameter.

Action: The **BL** command is used to prevent an accidental change of baud rate. The **BL** command must be preceded with an **EW** command. The **BL** set command must be addressed to 99, the global ID; this ensures that all units on a network are set to the same baud lock state.

Values: 0 = Baud rate can be changed with **BR** command.
1 = **BR** command is ignored.

Default: 0

Typical set command: *9900EW*9900BL=1

Typical set response: *9900EW (Echoed **EW** command)
*0001BL=1 (Response from device)
*9900BL=1 (Echoed command)

Typical read command: *0100BL

Typical read response: *0001BL=1

NOTE: The response shown above assumes that the RS-232 port is being used. If the RS-485 port were being used, no response would have been sent. Refer to section 11.3 for more information.

NOTE: The **BL** command affects both the RS-232 and the RS-485 ports.

ID Set the device ID.

Action: The ID command is used to set the device ID. The **ID** command must be addressed to 99, the global address. The device ID is set to the destination ID + 1. For example, if the command *9900ID were sent, the device would be set to ID=1 (00 + 1).

Range: 01 to 97

Default: 01

Typical set command: *9903ID (to set device ID to 04)

Typical set response: *9904ID (Indicates device ID was set to 04)

NOTE: The response shown above assumes that the RS-232 port is being used. If the RS-485 port were being used, no response would have been sent.

CAUTION Do not send the ID command when multiple devices are connected together in an RS-485 multi-drop network. Doing so will set all devices on the network to the same ID. Refer to Section 11.3 for more information about using the ID command in an RS-485 multi-drop network.

7.2.3. Engineering units commands

These commands are used to specify the engineering units to be used when calculating pressure or temperature values, and to configure the user-defined pressure unit.

UN Set or read the pressure engineering units.

Action: Sets or queries the conversion factor by which all calculated pressure values are multiplied before being output. Setting **UN** to a non-zero value selects one of eight standard pressure units; 0 selects a user-defined unit whose conversion factor is specified by the **UF** command. **UN** also sets the units of the pressure data displayed by an optional Model 715 display.

Range: 0 to 8

Table 6: UN Command Options

UN value	Pressure units	psi multiplied by...
0	User-defined pressure unit	Value of UF
1	psi	1.0000000
2	hPa (mbar)	68.94757
3	bar	0.06894757
4	kPa	6.894757
5	MPa	0.00689476
6	in Hg	2.036021
7	mm Hg (Torr)	51.71493
8	m H ₂ O	0.7030696

Default: 1

Typical set command: *0100EW*0100UN=2

Typical set response: *0001UN=2

Typical read command: *0100UN

Typical read response: *0001UN=2

UF Set or read the user-defined pressure engineering units conversion factor.

Action: When **UN**=0, calculated pressure values (psi) are multiplied by the value of **UF** before being output, thus scaling the pressure values in the desired user-defined pressure units.

Range: -9999999 to 9999999

Default: 1.0000000

Typical set command: *0100EW*0100UF=2

Typical set response: *0001UF=2.000000

Typical read command: *0100UF

Typical read response: *0001UF=2.000000

TU Set or read the temperature engineering units.

Action: Specifies the temperature units for **Q3**, **Q4**, **Q5**, and temperature data displayed by an optional Model 715 display.

Range: 0 = °C
1 = °F

Default: 0

Typical set command: *0100EW*0100TU=1

Typical set response: *0001TU=1

Typical read command: *0100TU

Typical read response: *0001TU=1

NOTE: Temperature is always calculated in °C, but it is converted to °F if **TU**=1.

7.2.4. Power management commands

DIGIQUARTZ Intelligent devices can be commanded to enter a reduced-power Sleep Mode during periods of serial port inactivity. The unit “awakens” 0.6 seconds after a single serial character is received on either port. Since the unit is “asleep” when the wake-up character is received, that character will be lost, and will not be interpreted as being part of a command. It is therefore necessary to send a character and wait at least 0.6 seconds before sending a command to an intelligent device that is in Sleep Mode.

CAUTION Power management features are not available if **MD** is set for continuous pressure data output or display data output, or Fetch Mode is enabled (**FM**=1).

SL Set or read the sleep mode enable state.

Action: Allows sleep mode to be enabled or disabled. When sleep mode is enabled, the device will enter sleep mode when both serial ports have received no characters for the number of seconds specified by the value of **ST**. When sleep mode is disabled, the device cannot enter sleep mode.

Range: 0 = sleep mode disabled
1 = sleep mode enabled

Default: 0

Typical set command: *0100EW*0100SL=1

Typical set response: *0001SL=1

Typical read command: *0100SL

Typical read response: *0001SL=1

NOTE: If **MD** is set for continuous pressure data output or display data output, or Fetch Mode is enabled (**FM=1**), the device will never enter sleep mode regardless of the values of **SL** or **ST**.

ST Set or read the sleep mode timeout length.

Action: When **SL=1**, the device enters sleep mode if both serial ports have received no characters for **ST** seconds.

Units: Seconds

Range: 5 to 255, integer values only.

Default: 10

Typical set command: *0100EW*0100ST=5

Typical set response: *0001ST=5

Typical read command: *0100ST

Typical read response: *0001ST=5

7.2.5. Tare and overpressure commands

Taring is the process of subtracting a specified value from pressure measurements. You may use a measured pressure as the tare value, or you may specify any desired value. Taring can be enabled, disabled, and locked out through the use of serial commands. Taring can also be controlled and monitored using I/O lines; please refer to Section 13 for more information. Pressure measurement data can be formatted to include an indication when taring is in effect. Refer to the **ZI** command for more information.

The overpressure command can be used to specify the overpressure alarm setpoint. When the overpressure setpoint is exceeded, the overpressure I/O line changes from logic low (0 VDC) to logic high (3.3 VDC). Refer to Section 13 for more information.

ZS Set or read the tare state parameter value.

Action: The three states of ZS are as follows:

- ZS=0 Taring function is off.
- ZS=1 Taring has been requested, but is not yet in effect.
- ZS=2 Taring is in effect

ZS is set to 0 on power-up. If **ZL**=0 (taring is not locked out), taring can be requested by sending the ZS=1 command. At the first pressure measurement following a tare request, the following sequence occurs:

- The pressure value is stored in the **ZV** parameter.
- The value of **ZS** is set to 2 to indicate that taring is in effect.
- The value of **ZV** is subtracted from all subsequent pressure values until taring is turned off.

If taring is already in effect when a **ZS**=1 command is issued, the sequence described above occurs, and taring continues using a new value of **ZV**.

Taring can be turned off by issuing a **ZS**=0 command.

Range: 0 to 2

Default: 0

Typical set command: *0100EW*0100ZS=1

Typical set response: *0001ZS=1

Typical read command: *0100ZS

Typical read response: *0001ZS=1

ZV Set or read the tare value.

Action: Sets or queries the value that is subtracted from pressure measurements when taring is activated. You can set **ZV** to any desired value when taring is in effect (**ZS**=2). Note, however, that if taring is subsequently requested, a new value will overwrite the **ZV** value you have set.

The value of **ZV** is set to 0 on power-up.

Range: -9999999 to 9999999

Default: 0

Typical set command: *0100EW*0100ZV=14.7123

Typical set response: *0001ZV=14.7123

Typical read command: *0100ZV

Typical read response: *0001ZV=14.7123

ZL Set or read the tare lockout parameter value.

Action: When **ZL**=0, **ZS** can be set to enable and disable taring. When **ZL**=1, the value of **ZS** cannot be modified via serial commands or the Tare Input I/O line. However, if **ZS**=1 and a **ZL**=1 command is issued, taring will be in effect when the next pressure measurement is taken, but you cannot turn taring off until **ZL** is set to 0.

The value of **ZL** is set to 0 on power-up.

Range: 0 or 1

Default: 0

Typical set command: *0100EW*0100ZL=1

Typical set response: *0001ZL=1

Typical read command: *0100ZL

Typical read response: *0001ZV=1

OP Set or read the overpressure alarm setpoint value.

Action: When a pressure measurement value is less than the value of **OP**, the Overpressure I/O line is at logic low (0 VDC); if it is greater or equal to the value of **OP**, the Overpressure I/O line is set to logic high (3.3 V DC). Refer to Section 13 for more information.

OP is set in the current pressure units, and is scaled accordingly if the engineering units are changed.

Range: -9999999 to 9999999

Default: Maximum rated device pressure

Typical set command: *0100EW*0100OP=15

Typical set response: *0001OP=15.00000

Typical read command: *0100OP

Typical read response: *0001OP=15.00000

NOTE: Command **OP** only checks for overpressure when MD \neq 0 or during pressure readings (**P3** or **P4**).

7.2.6. Measurement data formatting commands

These commands are used to alter the format of serial measurement data. The following data formatting functions are available:

- Append engineering units to pressure and temperature measurement data
- Append a taring indication to tared pressure measurement data
- Add underscores to separate the measurement data from the rest of the serial output data string to improve readability
- Add trailing zeroes to the measurement data to create a fixed-length data string to simplify parsing

Formatting commands can be used separately or in any combination.

US Set or read the engineering units suffix parameter value.

Action: When **US**=1, an engineering units label is appended to pressure and temperature measurement data. When **US**=0, no engineering units label is appended.

Examples: *000114.71234 (Pressure measurement, **US**=0)
*000114.71234psia (Pressure measurement, **US**=1)
*000121. 123 (Temp measurement, **US**=0)
*000121. 123C (Temp measurement, **US**=1)

When **US**=1, a pressure unit label is appended to pressure measurement values, according to the value of **UN**:

Table 7: Pressure Unit Suffixes

UN value	Label
0	Defined by UM
1	psia, psig, or psid
2	hPa
3	bar
4	kPa
5	MPa
6	inHg
7	mmHg
8	mH2O

When **US**=1, a temperature unit label is appended to temperature measurement values, according to the value of **TU**:

Table 8: Temperature Unit Suffixes

TU value	Label
0	C
1	F

Range: 0 or 1

Default: 0

Typical set command: *0100EW*0100US=1

Typical set response: *0001US =1

Typical read command: *0100US

Typical read response: *0001US =1

SU Set or read the underscore separator parameter value.

Action: When **SU**=1, an underscore separates the measurement data from the address header and the optional engineering units suffix. When **SU**=0, no underscore separators appear.

Examples: *000114.71234 (**SU**=0)
 *0001_14.71234 (**SU**=1)
 *0001_14.71234_psia (**SU**=1, **US**=1)

Range: 0 or 1

Default: 0

Typical set command: *0100EW*0100SU=1

Typical set response: *0001SU=1

Typical read command: *0100SU

Typical read response: *0001SU=1

ZI Set or read the taring indication parameter value.

Action: When **ZI**=1, an “T” is appended to pressure measurement values when taring is in effect. When **ZI**=0, no taring indication appears, whether taring is in effect or not.

Examples: *000114.71234 (**ZI**=0)
 *000114.71234T (**ZI**=1)
 *0001_14.71234T (**ZI**=1, **SU**=1)
 *000114.71234Tpsia (**ZI**=1, **US**=1)
 *0001_14.71234T_psia (**ZI**=1, **US**=1, **SU**=1)

Range: 0 or 1

Default: 0

Typical set command: *0100EW*0100ZI=1

Typical set response: *0001ZI=1

Typical read command: *0100ZI

Typical read response: *0001ZI=1

DL Set or read the fixed field data format parameter.

Action: When **DL**=1, measurement data is formatted in a fixed field format. When **DL**=0, measurement data is given in the standard format.

The fixed field format is specified as follows:

*AAAASDDDDDDDDDD, where

* = the asterisk character

A = destination and source address characters

S = sign of pressure data, either + or -

D = numeric representation of pressure data, either digits or a decimal point

Examples:	*000114.71234	(Pressure, DL =0)
	*0001+14.7123400	(Pressure, DL =1)
	*000121. 123	(Temperature, DL =0)
	*0001+21.1230000	(Temperature, DL =1)

Range: 0 or 1

Default: 0

Typical set command: *0100EW*0100DL=1

Typical set response: *0001DL=1

Typical read command: *0100DL

Typical read response: *0001DL=1

NOTE: Period measurement data will contain no sign.

NOTE: The format specification and examples shown above assume that the other formatting commands are disabled. If other formatting commands are used in combination with **DL**, a fixed field format will still result, but the format specification will vary slightly from the one described above.

UM Set or read the user-defined engineering units label parameter.

Action: When **UN**=0 and **US**=1, the text value of **UM** is appended to pressure measurements.

Examples: *000114.71234 (UN=0, US=0)
*000114.71234user (UN=0, US=1, UM=user)

Range: Any text up to four characters, consisting of ASCII 32 to ASCII 127.

Default: user

Typical set command: *0100EW*0100UM=test

Typical set response: *0001UM=test

Typical read command: *0100UM

Typical read response: *0001UM=test

7.2.7. Unit identification commands

The Unit Identification commands read various device-specific parameters. These commands are factory-set, and cannot be modified.

SN Read the serial number.

Action: The **SN** parameter contains the device serial number. **SN** is a read-only command.

Typical read command: *0100SN

Typical read response: *0001SN=12345

VR Read the firmware version number.

Action: The **VR** parameter contains the device firmware version number. **VR** is a read-only command.

Typical read command: *0100VR

Typical read response: *0001VR=R4.01

CF Read the firmware checksum.

Action: The **CF** parameter contains the firmware checksum. The value of **CF** is always 4 characters. **CF** is a read-only command.

Typical read command: *0100CF

Typical read response: *0001CF=A1B2

MN Read the model number.

Action: The **MN** parameter contains the device model number as a text string. The value of **MN** always contains 16 characters. If the model number is less than 16 characters, the string will be padded with trailing spaces to a length of 16 characters. **MN** is a read-only command.

Typical read command: *0100MN

Typical read response: *0001MN=6030A

PF Read the full-scale pressure value.

Action: The **PF** parameter contains the full-scale pressure value in the current pressure units. If the units are changed, the value of **PF** is scaled accordingly. **PF** is a read-only command.

Typical read command: *0100PF

Typical read response: *0001PF=30.00000

PO Read the pressure transducer type.

Action: The **PO** parameter contains the pressure transducer type. **PO** is a read-only command.

Table 9: PO Command Return Values

PO value	Transducer type
0	Absolute
1	Gauge
2	Differential

Typical read command: *0100PO

Typical read response: *0001PO=0

7.2.8. Time reference stamp command

NOTE: The time reference stamp feature is available in firmware version 4.10 or later.

A time reference stamp can be appended to pressure and temperature measurement data to help you determine when the pressure or period measurement was taken, relative to the transmission of the measurement command response. The time reference value reported is the time interval between the midpoint of the integration period and the start of the transmission of the first ASCII character of the response data.

TS Enables and disables the time reference stamp feature. The **TS** command affects the following measurement commands: **P1, P2, P3, P4, P5, P6, P7, Q1, Q2, Q3, Q4, Q5, and Q6.**

Action: When is enabled, a comma delimited time reference stamp is appended to the measurement values returned by the aforementioned commands, expressed in microseconds.

Range: 0 = Time reference stamp disabled
1 = Time reference stamp enabled

Typical set command: *0100EW*0100TS=1

Typical set response: *0001TS=1

Typical read command: *0100TS

Typical read response: *0001TS=1

The time reference value reported is the time interval between the midpoint of the integration period and the start of the transmission of the first ASCII character of the response data, expressed in microseconds. **DL=1** pads the time reference stamp value to 9 digits.

NOTE: The time reference stamp feature is not compatible with fetch mode. If **FM=1** (fetch mode active), >ERR:S1 is returned instead of the time reference stamp value.

Examples:

(Pressure = 14.74638, time reference stamp = 500637 microseconds)

P3 response, **DL=0**: *000114.74638,500637

P3 response, **DL=1**: *0001+14.746380000,000500637

Transmission delay

The response data as seen by the serial host is delayed by the time it takes to transmit the data. For high accuracy applications, it is necessary to compensate for this delay. The formula for calculating the transmission delay time is as follows:

$$T = (N * 10) (1E6/BR)$$

Where: T = transmission delay in microseconds
N = number of characters transmitted
BR = baud rate

Don't forget to consider the carriage return and line feed characters when determining the number of characters transmitted.

Processing delay

For high accuracy applications, it is also necessary to compensate for any delay by the serial host in acknowledging the first character of the response data.

7.2.9. Model 715 Display configuration commands

The Display Configuration commands configure the DIGIQUARTZ Intelligent device for use with an optional Model 715 display.

DM Set or read the display mode.

Action: The display mode determines which data (if any) is displayed on the second line of an optional Model 715 display. The following table describes the supported display modes:

Table 10: DM Command Options

DM	Display mode
0	Horizontal bar graph indicating measured pressure as a percentage of full-scale pressure.
1	Internal transducer temperature.
2	User-defined text defined by the UL parameter.
3	No data is displayed on second line.
4	User-defined text received with the DT command.
5	Current tare value
9	Minimum pressure since last reset
10	Maximum pressure since last reset

Default: 0

Typical set command: *0100EW*0100DM=1

Typical set response: *0001DM=1

Typical read command: *0100DM

Typical read response: *0001DM=1

DO Set or read the display output port.

Action: **DO** selects which serial port (RS-232 or RS-485) will produce data for the Model 715 display. The other serial port is normally used for communication with a host device, such as a PC. When **DO=0**, the RS-485 port is used for Model 715 display data; when **DO=1**, the RS-232 port is used.

Range: 0 or 1

Default: 0

Typical set command: *0100EW*0100DO=1

Typical set response: *0001DO=1

Typical read command: *0100DO

Typical read response: *0001DO=1

NOTE: When **DO=0**, continuous pressure measurement data produced by **MD=2** and **MD=3** is output on the RS-232 port. When **DO=1**, continuous pressure measurement data produced by **MD=2** and **MD=3** is output on the RS-485 port.

DP Set or read the number of decimal places in the pressure data sent to the Model 715 display.

Action: **DP** sets the maximum number of decimal places in the pressure display data. Fewer decimal places will be displayed if the pressure resolution is not sufficient to provide the specified number of decimal places. When **DP** is set to 6, the maximum number of decimal places is always displayed.

Range: 0 to 6

Default: 6

Typical set command: *0100EW*0100DP=6

Typical set response: *0001DP=6

Typical read command: *0100DP

Typical read response: *0001DP=6

DT Set the text to be displayed on line 2 of the Model 715 display when DM=4.

Action: **DT** allows a serial host (such as a PC) to send text to the second line of an optional Model 715 display when **DM**=4. The text sent with **DT** is not stored by the intelligent device, it is simply transferred to the display. Since the text sent with **DT** is not stored, it cannot be queried, and it is not necessary to precede **DT** with an **EW** command.

Range: 16 characters maximum. Any characters in the range of ASCII 32 to ASCII 127 are legal.

Typical set command: *0100DT=This is my text

Typical set response: *0001DT=This is my text

PL Read the display overpressure indication setpoint. This setpoint is used to determine the pressure at which the intelligent device sends an overpressure indication to an optional Model 715 display.

Action: **PL** is a factory-set, read-only command. The value of the **PL** parameter is used as the overpressure indication setpoint for the Model 715 display.

Typical read command: *0100PL

Typical read response: *0001PL=120.0000

NOTE: **PL** is typically factory-set to 1.2 times full-scale pressure.

UL Set or read the text to be displayed on line 2 of the Model 715 display when **DM=2**.

Action: **UL** defines the text to be displayed on line 2 of an optional Model 715 display when **DM=2**. The value of **UL** is stored in non-volatile memory, and will therefore be retained even if power is lost. The value of **UL** is sent to the optional Model 715 display each time the pressure data is updated.

Range: 11 characters maximum. Any characters in the range of ASCII 32 to ASCII 127 are legal.

Default: 11 space characters

Typical set command: *0100EW*0100UL=My label

Typical set response: *0001UL=My label

Typical read command: *0100UL

Typical read response: *0001UL=My label

7.3. Serial data output mode command

The following command controls whether pressure data is continuously output, and whether display data are produced.

MD Set or read the serial data output mode.

Action: **MD** configures the intelligent device for continuous pressure measurement output and/or display data output whenever power is applied.

Table 11: MD Command Options

MD value	Model 715 display data output	Continuous pressure data output
0	Off	Off
1	On	Off
2	Off	On
3	On	On

Once **MD** is set, the specified serial data output mode will remain in effect until **MD** is set to a different value, even through a power cycle. Therefore, the device will perform the specified serial data output function whenever power is applied.

Default: 0

Typical set command: *0100EW*0100MD=1

Typical set response: *0001MD=1

Typical read command: *0100MD

Typical read response: *0001MD=1

CAUTION Do not configure any device on a 2 -wire RS-485 network for continuous pressure data output from the RS-485 port on power-up (**MD** = 2 or **MD**=3, **DO**=1). If you do this, it is unlikely that you will be able to reconfigure the unit over the network, since any command is likely to collide with the pressure data being continuously sent. To recover, you will need to remove the device from the network and reconfigure it individually via the RS-232 port.

NOTE: When **MD** is set to a non-zero value, the specified serial data output mode will be preempted under the following conditions:

- When the intelligent device is running in a continuous pressure data output mode, continuous data output is suspended when a measurement command is received. Continuous data output resumes when the measurement command is complete.
- When the intelligent device is running in a display data output mode, display data output is suspended when a period measurement command (P1, P2, P6, Q1, Q2, Q6) is received. Display data output resumes when the period measurement command is complete.
- Continuous pressure data output is suspended when a continuous measurement command (P2, P4, P7, Q2, Q4) is received, and resumes when the continuous measurement command is cancelled.

NOTE: When **DO**=0, continuous pressure measurement data produced by **MD**=2 and **MD**=3 is output on the RS-232 port. When **DO**=1, continuous pressure measurement data produced by **MD**=2 and **MD**=3 is output on the RS-485 port.

7.4. Diagnostic commands

In the unlikely event of a hardware failure, the Diagnostic commands can assist in the troubleshooting process.

CS Read the number of unused bytes on the stack since power-up.

Action: **CS** is read-only; it cannot be set. It can be used to determine whether a stack overflow may have occurred.

Typical read command: *0100CS

Typical read response: *0001CS=8

7.5. Calibration commands

The calibration commands set and read several parameters that directly affect the measurement accuracy of the device. Refer to Sections 17 and 18 for more information regarding the use of the calibration parameters.

CAUTION Calibration values should be modified only when absolutely necessary, and then with extreme caution. Calibration adjustments should only be performed by a qualified metrology lab.

PA Set or read the pressure adder parameter.

Action: The pressure adder parameter is used to make zero adjustments to the calibration. **PA** can also be used to offset absolute pressure measurements by atmospheric pressure to obtain gauge pressure.

PA and **PM** are used in the following formula to calculate final output pressure:

$P_{\text{output}} = \text{PM} * (P + \text{PA})$, where

Where: P = Pressure calculated using original calibration coefficients, in the current pressure units

PM = the current value of the **PM** parameter

PA = the current value of the **PA** parameter

Range: -9999999 to 9999999

Default: 0.0

Typical set command: *0100EW*0100PA=.0000123
Typical set response: *0001PA=.0000123
Typical read command: *0100PA
Typical read response: *0001PA=.0000123

NOTE: The value of **PA** is entered in the current pressure units, but is converted to psi prior to being stored. When **PA** is queried, it returns the value scaled to the current pressure units.

PM Set or read the pressure multiplier parameter.

Action: The pressure multiplier parameter is used to make span adjustments to the calibration. See the formula in the **PA** command description.

Range: -9999999 to 9999999

Default: 1

Typical set command: *0100EW*0100PM=1.000123
Typical set response: *0001PM=1.000123
Typical read command: *0100PM
Typical read response: *0001PM=1.000123

NOTE: The value of **PM** is dimensionless, and is therefore not scaled if the units are changed.

TC Read the crystal timebase correction factor.

Action: **TC** is used to normalize the nominal 14.7456 MHz reference crystal frequency to 10 MHz to compensate for the natural variation in crystal resonant frequency. **TC** is a read-only command.

Typical read command: *0100TC
Typical read response: *0001TC=.6666667

C1 Set or read the calibration coefficients.
C2
C3
D1
D2
T1
T2
T3
T4
T5
U0
Y1
Y2
Y3

Default: Device-specific

Typical set command: *0100EW*0100C1=228.1234

Typical set response: *0001C1=228.1234

Typical read command: *0100C1

Typical read response: *0001C1=228.1234

7.6. Global commands

Under certain circumstances, it may be necessary to send a single command to multiple Intelligent devices on a serial loop or multi-drop network. The ID 99 has been reserved for such global addressing. When an Intelligent device receives a legal command addressed to ID 99, the device reacts to that command regardless of its assigned ID value.

To support the unique requirements of RS-232 serial loop and RS-485 multi-drop networking, Intelligent devices react to global commands differently depending on which port received the command. When a global command is received via RS-232, the global command is re-transmitted before acting on the command. This ensures that all devices on a serial loop will receive the global command. When a global command is received via RS-485, the Intelligent device acts on the command but does not send a response. This prevents multiple devices on a multi-drop network from transmitting simultaneously, which would result in data collisions and unintelligible data.

Some commands can only be sent with global addressing:

BR, BL, ID

Global addressing is often used with sample and hold measurement commands to synchronize measurements from multiple devices. The sample and hold measurement commands are:

P5, P6, Q5, Q6

All sampling commands and certain other commands may be either individually or globally addressed:

P1 through P7, Q1 through Q6, DB, DS, VR, EW

NOTE: **DS** is available in firmware version R3.00 and later.

CAUTION Global sampling commands sent to multiple units on an RS-485 multi-drop network may result in data collisions when multiple devices respond simultaneously.

8. Nano-Resolution Features & Functions

8.1. Introduction

Starting with firmware revision R5.10 or later, it is now possible to achieve parts-per-billion resolution (nano-resolution). This feature can be enabled by software command. When disabled, the sensor is backward compatible and works in the standard mode with typical parts-per-million resolution. Nano-resolution is achieved by sub-sampling the pressure at a much higher rate (typically 8 kHz) and applying digital signal processing techniques. Because of the much higher processing requirements, more input power is required. In general, the nano-resolution feature is only useful if the pressure is stable enough over the effective sampling period and if the data acquisition system can handle additional digits. The practical bandwidth of interest is in the infrasound and deep infrasound (10 to 0.001 Hz).

Two methods for nano-resolution are available. The first method processes the sub-samples in a finite time interval (analogous to the integration time of the standard mode). The digital process is an FIR filter (finite impulse response). The resolution can be directly compared to the resolution of the standard mode at the same sampling rate (synchronized). The algorithm performs a least-squares (regression) fit over the sub-samples to estimate the best value of pressure. While the resolution is statistically two orders of magnitude better than the standard mode, it does not suppress aliasing errors.

A second and usually preferred method is the IIR filter (infinite impulse response). It consists of a 5-stage digital low-pass filter acting on the sub-samples. It filters all frequencies with a roll-off of -100 dB/decade above a user selectable cutoff frequency. It is an effective anti-aliasing filter. The inherent resolution depends on the cutoff frequency and not on the sampling period. Typically, the sampling rate is set at twice the cutoff frequency (Nyquist limit).

8.2. Enabling Nano-Resolution

Nano-resolution can be enabled and disabled by the XM serial command.

XM Set or read the resolution mode.

Range: 0 = Standard Resolution Mode (backward compatible)

1 = Nano-resolution, IIR Filter Mode

2 = Nano-resolution, FIR Filter Mode

Default: 0

Typical set command: *0100EW*0100XM=1

Typical set response: *0001XM=1

Typical read command: *0100XM

Typical read response: *0001XM=1

8.3. Configuring IIR Filter Mode

SETTING RESOLUTION

Resolution is a function of the cutoff frequency when operating in IIR mode. The cutoff frequency is user-selectable and is set by the IA command.

IA Set or read the cutoff frequency setting.

Range: 0 - 16

Default: 11

Typical set command: *0100EW*0100IA=11

Typical set response: *0001IA=11

Typical read command: *0100IA

Typical read response: *0001IA=11

See Table 12 for a list of ranges for IA values, cutoff frequencies, measurement resolution, and the number of digits reported.

Table 12: IIR Filter Mode Typical Resolution Ranges

IA	Cutoff Frequency ⁽¹⁾	Effective Time Interval ⁽²⁾	Period Resolution ⁽³⁾	Measurand Resolution ⁽⁴⁾	Measurand Resolution ⁽⁴⁾	Pressure & Temp Digits ⁽⁵⁾
	(Hz)	(ms)	(dB)	(dB)	(ppm/ppb)	
0	1400	0.1	-82	-62	790 ppm	6
1	700	1	-94	-74	200 ppm	7
2	350	2	-105	-85	56 ppm	7
3	175	3	-117	-97	14 ppm	8
4	88	6	-127	-107	4.5 ppm	8
5	44	11	-140	-120	1.0 ppm	8
6	22	22	-149	-129	0.35 ppm	9
7	11	44	-157	-137	0.14 ppm	9
8	5.5	89	-167	-147	45 ppb	10
9	2.8	178	-177	-157	14 ppb	10
10	1.4	350	-186	-167	4.5 ppb	11
11	0.7	700	-196	-176	1.6 ppb	11
12	0.35	1400	-203	-183	0.7 ppb	12
13	0.18	2800	-206	-186	0.5 ppb	12
14	0.09	5600	-207	-187	0.4 ppb	12
15	0.045	11200	-207	-187	0.4 ppb	12
16	0.023	22400	-207	-187	0.4 ppb	12

- (1) Cutoff frequency is the -3dB point of the low-pass IIR filter.
- (2) Effective Time Interval is the recommended minimum time interval between measurements that ensures sampling up to the specified cutoff frequency. The time interval is set using the PI command.
- (3) Period Resolution is the resolution of pressure and temperature period measurements.
- (4) Measurand Resolution is the resolution of pressure and temperature measurements.
- (5) Pressure and Temperature Digits is the total number of digits used to report pressure and temperature measurements. Pressure and temperature period measurements contain one additional digit.

8.4. Configuring FIR Filter Mode

SETTING RESOLUTION

Resolution is a function of the integration time when operating in FIR mode. The integration time is set by the PI command. Refer to page 7-8 for more information about the PI command.

Table 13 lists various PI values and the resulting measurement resolution for pressure period, pressure, and the number of digits reported.

Table 13: FIR Filter Mode Typical Resolution Ranges

PI	Period Resolution ⁽¹⁾	Measurand Resolution ⁽²⁾	Measurand Resolution ⁽²⁾	Pressure & Temp Digits ⁽³⁾
(ms)	(dB)	(dB)	(ppm/ppb)	
1	-105	-85	56 ppm	6
2	-114	-94	20 ppm	7
3	-119	-99	11 ppm	7
6	-128	-108	3.8 ppm	8
11	-136	-116	1.5 ppm	8
22	-145	-125	545 ppb	8
44	-154	-134	193 ppb	9
89	-163	-143	67 ppb	9
178	-173	-153	24 ppb	10
350	-181	-161	8.6 ppb	10
700	-190	-170	3.0 ppb	11
1400	-199	-179	1.1 ppb	11
2800	-206	-186	0.5 ppb	12
5600	-206	-186	0.5 ppb	12
11200	-206	-186	0.5 ppb	13
22400	-206	-186	0.5 ppb	13

- (1) Period Resolution is the resolution of pressure and temperature period measurements.
- (2) Measurand Resolution is the statistical resolution limit of the FIR algorithm for pressure and temperature measurements. The trigger error typically doubles the least resolution.
- (3) Pressure and Temperature Digits is the total number of digits used to report pressure and temperature measurements. Pressure and temperature period measurements contain one additional digit up to a maximum of 13 digits.

TEMPERATURE SMOOTHING

The temperature smoothing function is available for additional low-pass filtering of the temperature signal, mostly to avoid very rare and small aliasing errors from digital rounding in the FIR mode. The XT command enables and disables the smoothing function and controls the corner frequency of the low-pass filter. Normally, the default setting should always be XT=1 (no smoothing). If temperature smoothing is desired, a setting of XT=10 is suggested.

Temperature smoothing is performed per the following formula:

$$S_n = \alpha T_n + (1 - \alpha) S_{(n-1)}$$

Where S_n = smoothed temperature
 T_n = measured temperature
 $S_{(n-1)}$ = smoothed temperature of previous sample
 $\alpha = 1/(XT)$

XT Set or read the number of temperature measurements to use for temperature smoothing in FIR Mode.

Range: 1 - 100

Default: 1 (no smoothing)

Typical set command: *0100EW*0100XT=10

Typical set response: *0001XT=10

Typical read command: *0100XT

Typical read response: *0001XT=10

8.5. Default Numeric Formats for IIR & FIR Modes

The default numeric formats used to report period, pressure, and temperature measurement values are as follows, where N = the number of significant digits shown in the resolution tables.

PRESSURE

The sensor full-scale pressure defines the number of digits reserved for the integer portion of the pressure value. For example, a 1000 psi full-scale unit would have 4 digits reserved (but not necessarily used) for the integer portion of the pressure value, leaving N-4 digits for the fractional portion.

TEMPERATURE

Three digits are reserved (but not necessarily used) for the integer portion of the temperature value, leaving N-3 digits for the fractional portion. Negative temperature values include a sign but the numeric format is otherwise unaffected.

PRESSURE PERIOD

Two digits are used for the integer portion of the pressure period value, leaving N-2 digits for the fractional portion.

TEMPERATURE PERIOD

One digit is used for the integer portion of the pressure period value, leaving N-1 digits for the fractional portion.

8.6. Controlling the Numeric Format

The XN command sets the number of significant digits used to report period, pressure, and temperature measurement values. The XN command overrides the default numeric format.

XN Set or read the number of significant digits.

Range: 0 - 13

Default: 0

Typical set command: *0100EW*0100XN=10

Typical set response: *0001XN=10

Typical read command: *0100XN

Typical read response: *0001XN=10

When XN is set to 0, the default numeric formats are used. When non-zero, XN specifies the number of significant digits used to report period, pressure, and temperature measurement values. With the exception of the total number of digits, all default format characteristics apply. The integer portion is never expressed with fewer digits than required regardless of the value of XN. The fractional portion is rounded or padded with zeros as required to fit the specified format. The XN command works with Standard, IIR, and FIR resolution modes.

9. Resolution, Integration Time, and Sampling Rate

The outputs from DIGIQUARTZ pressure transducers are two square wave signals whose period is proportional to applied pressure and internal transducer temperature. The Intelligent electronics measures these signals using a technique similar to that of a common laboratory frequency counter. Like the frequency counter, a signal must be integrated for a specified period of time to measure its period.

The time over which the signal is integrated determines the resolution of the measurement. Longer integration times increase resolution, but reduce the sampling rate. Conversely, shorter integration times decrease resolution, but increase the sampling rate.

The integration mode has a significant effect on sampling rate. The effective sampling rate of Simultaneous Integration (OI=0) is roughly double that of Sequential Integration Simulation (OI=1) for a given PI or PR setting, until the maximum serial bandwidth is reached. Note that the relationship between integration time and pressure resolution is not affected by the integration mode. Please refer to Sections 4.3 and 7.1.6 for more information about Sequential Integration and Simultaneous Integration Simulation.

Another factor that influences sampling rate is the serial baud rate. For short integration times, faster baud rates enable faster sampling. As integration times increase, the benefit of faster baud rates quickly diminishes.

Table 14 illustrates the relationship between integration time, resolution, and sampling rate for the **P4** command in Simultaneous Integration and Sequential Integration Simulation modes at various baud rates.

P4 Command (Continuous Pressure Output)

Table 14: Relationship of Integration Time, Resolution, and Sampling Rate for P4 Command

PI	Resolution (ppm)		Integration Time (sec)		Sampling Rate (Hz)					
					9600 Baud		57600 Baud		115200 Baud	
	Ol=0	Ol=1	Ol=0	Ol=1	Ol=0	Ol=1	Ol=0	Ol=1		
1	339.100	678.200	0.001	0.002	106.70	106.70	442.90	315.50	449.40	310.30
3	113.000	226.100	0.003	0.006	106.70	106.70	236.80	138.60	236.40	137.40
8	42.390	84.770	0.008	0.016	87.30	58.00	108.80	58.00	108.00	58.00
11	30.830	61.650	0.011	0.022	81.80	42.90	81.80	42.90	81.80	42.90
17	19.950	39.890	0.017	0.034	55.10	21.80	55.10	21.80	55.10	21.80
34	9.970	19.950	0.034	0.068	28.40	14.40	28.40	14.40	28.40	14.40
67	5.060	10.120	0.067	0.134	14.60	7.37	14.60	7.37	14.60	7.37
134	2.530	5.061	0.134	0.268	7.38	3.71	7.38	3.71	7.38	3.71
333	1.018	2.037	0.333	0.666	2.99	1.50	2.99	1.50	2.99	1.50
666	0.509	1.018	0.666	1.332	1.50	0.75	1.50	0.75	1.50	0.75
1333	0.254	0.509	1.333	2.666	0.75	0.38	0.75	0.38	0.75	0.38
3332	0.102	0.204	3.332	6.664	0.30	0.15	0.30	0.15	0.30	0.15
6664	0.051	0.102	6.664	13.328	0.15	0.08	0.15	0.08	0.15	0.08
13328	0.025	0.051	13.328	26.656	0.08	0.04	0.08	0.04	0.08	0.04
26656	0.013	0.025	26.656	53.312	0.04	0.02	0.04	0.02	0.04	0.02
45872	0.007	0.015	45.872	91.744	0.02	0.01	0.02	0.01	0.02	0.01

NOTES: Please refer to Sections 4.3 and 7.1.6 for more information about Simultaneous Integration and Sequential Integration Simulation. The measurement time interval (seconds) is equal to 1 / Sampling Rate (Hz). Data in this table assume TI=PI and version R5.00 or later. PR is approximately equal to PI x 2.8

10. High-Speed Sampling

Use one or more of the following techniques to increase sampling rate:

- Select Simultaneous Integration. Refer to the **OI** command in Section 7.1.6.
- Turn off any data being sent to the Model 715 display. Refer to the **MD** command in Section 7.3.
- Increase the baud rate. Refer to the **BR** command in Section 7.2.2.
- Reduce integration time. Refer to **PI**, **TI**, **PR**, and **TR** commands in Section 7.1.4.
- Use a continuous pressure measurement command, such as **P4**. See section 7.1.3.
- Use the continuous pressure period command (**P2**), and post-process data to convert to pressure. Refer to Section 17 for detailed information about converting period measurements into pressure values.
- Turn off the time reference stamp (**TS**) function. Refer to Section 7.2.8.

11. Networking Multiple Intelligent Devices

DIGIQUARTZ Intelligent devices support RS485 multi-drop and RS-232 serial loop networking. Both types of networking allow you to address up to 98 DIGIQUARTZ Intelligent devices from a single serial host.

11.1. Networking basics

When setting up a network, the following points must be observed, regardless of whether you choose RS-485 multi-drop or RS-232 serial loop networking.

- If your network includes older Intelligent devices that support RS-232 only, set the older devices to **PT** = N to assure compatibility with newer devices.
- Verify proper operation of each Intelligent device before installing it in a network.
- Set all Intelligent devices to the same baud rate before installing them in a network. Once your network is up and running, you can change the baud rate to any supported value.
- Each Intelligent device on the network needs to be set to a unique ID.
 - If you are setting up an RS-232 serial loop network, you can automatically set all devices to a unique ID value by issuing a single ID command.
 - If you are setting up an RS-485 multi-drop network, you must isolate each device from the network, and set the ID of each device individually.

See Section 7.2.2 for more information about the ID command.

11.2. Choosing a networking type

Both types of networking have unique benefits, as described below. Carefully consider your system requirements before selecting a networking type.

Benefits of RS-485 multi-drop networking:

- RS-485 transmission distance is up to 4,000 feet, compared to 50 feet for RS-232 serial loop networking.
- Improved data integrity in electrically noisy environments, as compared to RS-232 serial loop networks.
- Can take synchronized measurements from any or all devices on the network. This is not possible with RS-232 serial loop networking due to the delays that occur as the measurement command propagates through the network.

- Can wake up all sleeping devices with a single character. Each device must be awakened individually on an RS-232 serial loop network.
- Improved system reliability. It is less likely that a failure in a single unit will affect the entire network, as compared to RS-232 serial loop networks.

Benefits of RS-232 serial loop networking:

- RS-232 serial loop networking is compatible with all standard PCs, and most other control devices. RS-485 may not be available or may require additional hardware, depending on the serial host you have selected.
- Unique device IDs can be assigned to all devices on the network with a single command. With an RS-485 multi-drop network, you must isolate each unit and assign its unique ID individually.
- Can directly communicate with up to 98 devices. You can address up to 98 devices with RS-485, but you must use a repeater if you have more than 32 devices (including the host) on the network.

11.3. RS-485 multi-drop networking

As shown in Section 11.2, RS-485 multi-drop offers several significant benefits over RS-232 serial loop networking. It is recommended that RS-485 multi-drop networking be used whenever possible.

RS-485 multi-drop networks can be wired as a 2-wire or 4-wire system. DIGIQUARTZ Intelligent devices are compatible with either system. Refer to Section 15.4 for multi-drop wiring diagrams.

11.3.1. Characteristics unique to RS-485 multi-drop networking

When setting up and operating an RS-485 multi-drop network, please be aware of the following:

- Up to 98 devices can be addressed on an RS-485 multi-drop network, but a maximum of 31 devices can be driven by any single transmitter. If you intend to build a network that exceeds 31 DIGIQUARTZ Intelligent devices, you must use one or more RS-485 repeaters to ensure that no device is driving more than a maximum of 31 receivers.
- **CAUTION** Do not attempt to set ID values over a multi-drop network. Doing so will set all devices on the network to the same ID value. To set each device to a unique ID, isolate each device from the network, and individually set its ID value.
- **CAUTION** Do not send continuous measurement commands (**P2**, **P4**, **P7**, **Q2**, **Q4**) to any device on a 2-wire multi-drop network. If you do this, you may need to cycle power to stop the continuous transmission of measurement data, since the command from the host to stop continuous measurement will likely collide with the measurement data coming from the device. This is especially true if your device is set for a short integration time.
- **CAUTION** Do not configure any device on a 2-wire RS-485 network for continuous pressure data output from the RS-485 port on power-up (**MD** = 2 or **MD**=3, **DO**=1). If you do this, it is unlikely that you will be able to reconfigure the unit over the network, since any command is likely to collide with the pressure data being continuously sent. To recover, you will need to remove the device from the network and reconfigure it individually via the RS-232 port.

11.3.2. 2-wire RS-485 multi-drop networking

DIGIQUARTZ Intelligent devices support half-duplex, master-slave communications with serial hosts. This means that the Intelligent device, or slave, will only transmit if it has been commanded to do so by the serial host, or master. This feature enables Intelligent devices to be used in 2-wire RS-485 systems, where commands sent from the host and responses sent by the Intelligent device are sent on the same pair of wires.

Figure 18 in Section 15.4 illustrates a two-wire RS-485 multi-drop network consisting of a host and multiple DIGIQUARTZ Intelligent devices. Notice that the TX+ and RX+ signals and the TX- and RX- signals are tied together at each device, forming a 2-wire interface. The 2-wire configuration can reduce wiring costs, but the system designer must take precautions as described below to ensure reliable communications.

Data collisions occur on 2-wire RS-485 systems when two or more devices transmit simultaneously. The result of a data collision is that both transmissions become unintelligible and are lost. In a master-slave network, it is the responsibility of the serial host to ensure that data collisions do not occur. Normally, this requires that the host wait an appropriate length of time for a response before sending another command.

Since multiple transmitters share common wiring in 2-wire RS-485 multi-drop systems, it is necessary that all devices on a network have the ability to disable their transmitters when not actively transmitting. DIGIQUARTZ Intelligent devices perform this task automatically, but the serial host must also enable its transmitter only when transmitting. Some RS-485 devices, particularly low-cost RS-232 to RS-485 converters, tend to leave their transmitters enabled for a period of time after RS-485 data has been transmitted. If this time is sufficiently long, some or all of the response data from a DIGIQUARTZ Intelligent device will not be received by the serial host, since the host will still be in the transmit mode when the response is being sent. If you plan to use such a device, reliable two-wire RS-485 communications may not be possible, and you will need to use a 4-wire system instead.

11.3.3. 4-wire RS-485 multi-drop networking

Figure 19 in Section 15.4 illustrates a 4-wire RS-485 multi-drop network consisting of a host and three DIGIQUARTZ Intelligent devices. In this system, there is no need for the host to disable its transmitter, since it is connected to the receive lines of the Intelligent devices via a dedicated pair of wires.

11.4. RS-232 serial loop networking

RS-232 serial loop networking can be used when RS-485 communications are not available or are impractical, and provides network compatibility with previous DIGIQUARTZ Intelligent devices that do not support RS-485.

Refer to Figure 2 below. In an RS-232 serial loop network, the transmit output of the RS-232 host is connected to the receive input of the first device in the loop. The transmit output of the first device is connected to the receive input of the next device. The remaining devices are connected similarly, with their receive input connected to the transmit output of the previous device, and their transmit output connected to the receive input of the next device. The transmit output of the last device is connected to the receive input of the RS-232 host.

The host sends commands to the first device in the loop. If a command is addressed to that device, the command is carried out; if not, the command is resent to the next device. Globally addressed commands are carried out by each device, and are also resent to the next device. When a device responds to a command, the response is addressed to the host, and is therefore resent by each device that receives it until it eventually makes it way to the serial host.

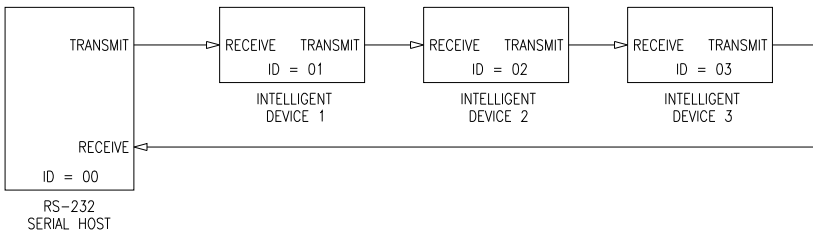

Figure 2: Serial loop network block diagram

There are several points to keep in mind when designing an RS-232 serial loop network:

- As previously described, each device resends any command or response that is addressed to another device. Since each device considers resending to be a higher priority than sending its own response, it is possible that a device can spend all its time resending, and never have an opportunity to send its own response. This occurs only when one or more upstream devices are continuously transmitting. To prevent this situation:
 - Operate your network at 9,600 baud or above
 - Avoid continuous transmission (**P2**, **P4**, **P7**, **Q2**, and **Q4** commands) at extremely low integration times

- Serial loop networking is limited to baud rates of 19,200 and below.
- A single **ID** command will automatically set all devices on the serial loop to unique sequential IDs.
- It is not possible to precisely synchronize measurements from two or more devices by sending a global measurement command. This is a result of the delay that occurs as the measurement command propagates through the serial loop. If precise measurement synchronization is required, consider an RS-485 multi-drop network instead.
- When a global command is sent, it propagates through the serial loop, eventually making its way back to the host. Therefore, the data received by the host in response to a global command includes the command itself, followed by the individual responses from all devices on the network.
- Sleeping devices on a serial loop network must be awakened individually, and in sequence, by sending a complete command to each device, starting with the first device. Keep in mind that a serial loop network will not be fully operational unless all devices on the network are awake, since response data will not be resent by sleeping devices downstream.
- DIGIQUARTZ Interactive software (DQI) is not capable of waking multiple sleeping devices on a serial loop network. If you intend to use DQI to communicate with units on a serial loop network, please ensure that all devices have the sleep mode disabled.

11.5. Other networking methods

Multiple serial ports

PC expansion boards are available which provide up to 32 individual RS-232 serial ports. Using such a board, it would be possible to design a system whereby each Intelligent device would be connected to the serial host via its own RS-232 port. This type of a system would ensure that any communications port, cable, or transmitter failure would not affect the rest of the system.

Relay Multiplexer System

For high-reliability applications with a large number of transmitters, it may be desirable to use a custom relay multiplexer as a switching hub to select separate data lines running out to the individual transmitters or serial loops in the system. Loss of any one data line through accident or failure will affect only those transmitters on that data line.

12. Using the Model 715 Display

The Model 715 is extremely simple and easy to use. There are no controls to set or configure. Simply connect the display to an appropriately configured DIGIQUARTZ Intelligent device and a DC power source, and the Model 715 will display the desired information.

The Model 715 can communicate with a DIGIQUARTZ Intelligent device via either RS-232 or RS-485. You can therefore use either port to communicate with the Model 715. The Model 715 automatically sets its baud rate to match that of the DIGIQUARTZ Intelligent device.

The Model 715 provides a regulated 6.0 VDC output for powering a DIGIQUARTZ Intelligent device, eliminating the need to power the Intelligent device separately.

12.1. Serial and power connections

DC power (7 – 25VDC, 270 mA max.) can be applied to a terminal block on the rear panel, or can be supplied by a 110VAC or 220 VAC wall power supply (part numbers 6377-001 or 6377-004).

Refer to Section 15.5 for Model 715 interconnection options.

12.2. Configuring an Intelligent device for use with the Model 715

DIGIQUARTZ Intelligent devices must be configured to be used with the Model 715 display. The following commands are available for this purpose:

- MD** Enables output of display data. **MD** must be set to 1 or 3 for use with the Model 715 display. Refer to Section 7.3 for details.
- DO** Selects either RS-232 or RS-485 communication with the Model 715. Set **DO** to 0 to communicate with the Model 715 display via the RS-485 port, or set **DO** to 1 to use the RS-232 port.
- DM** Selects the type of information to be displayed on the second line of the Model 715 display.
- DP** Selects the number of decimal points in displayed pressure measurements.

Refer to Section 7.2.8 for details on the **MD**, **DO**, **DM**, and **DP** commands.

NOTE: Do not set **PI** to a value of less than 10 when using a Model 715 display. Doing so may result in an inconsistent display. For reliable operation, do not set baud rate (**BR**) to 115200 when using a Model 715 display.

12.3. Model 715 panel mounting instructions

Overview

The Model 715 can be adapted for use in panel or rack-mounted applications. This section provides the necessary mounting information.

Panel Preparation

Modify the mounting panel per the drawing in Figure 3. All dimensions are in inches.

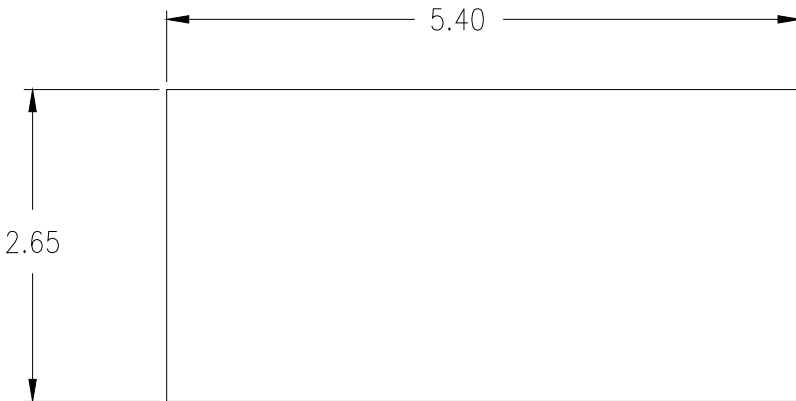

Figure 3: Model 715 Panel Cutout Detail

Mounting Procedure

1. Remove back feet

Remove the rear rubber feet from the Model 715. The feet are glued to the Model 715 and can be reattached in the future if needed.

2. Remove Set Screws

Using a 1/16" hex key, remove the two setscrews on the rear panel as shown in Fig. 2. Slide out the panel mount brackets from the sides of the Model 715 (see Figure 4 below).

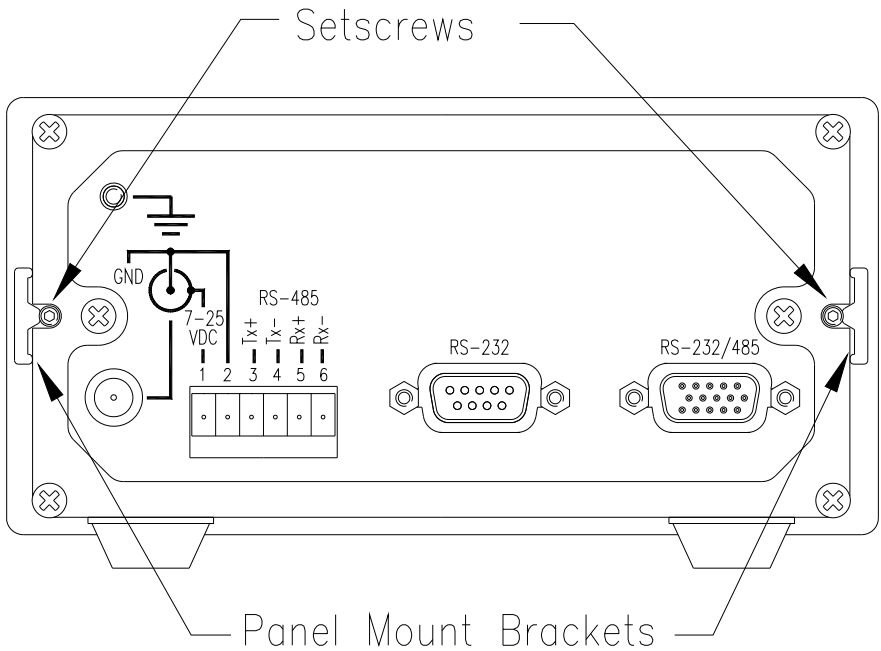

Figure 4: Model 715 Rear Panel Detail

3. Insert the Model 715 through the panel

Insert the back end of the Model 715 through the front of the panel cutout.

4. Replace the panel mount brackets

Slide the panel mount brackets into the slot on the side of the Model 715 and up against the panel.

5. Install setscrews

Insert the setscrews into the panel mount bracket and tighten.

13. I/O Lines

DIGIQUARTZ® Intelligent Transmitters feature discrete digital I/O lines that may be used to control and monitor tare and overpressure alarm functions. See Section 7.2.5 for more information regarding tare and overpressure functions.

NOTE: DIGIQUARTZ Intelligent Depth Sensors do not support the I/O lines described in this section.

INPUT

Tare Input – Activated by a momentary contact closure to ground. When taring is not in effect and Tare Input is activated, taring is enabled on the next pressure measurement. When taring is in effect and Tare Input is activated, taring is disabled, and the next pressure measurement taken will not be tared.

WARNING To prevent possible damage, do not connect any voltage source other than DC power ground to the Tare Input.

OUTPUTS

Tare Output – Indicates whether the most recent pressure measurement was tared. The tare output is set to logic high when taring is in effect, is set to logic low when taring is not in effect.

Overpressure Output – Indicates whether the most recent pressure measurement exceeds the user-specified overpressure setpoint. The overpressure output is set to logic high if overpressure setpoint is exceeded, and is set to logic low otherwise. See the **OP** command in Section 7.2.5 for more information.

Logic low: < 0.1 VDC

Logic high: 3.3 VDC

Maximum output drive current: 300 μ A (microamps)

14. Connector Diagrams

This section provides pin assignment diagrams for DIGIQUARTZ Intelligent devices and standard PCs. PC pin assignments are typical; if in doubt, consult the hardware manual that came with your PC.

NOTE: All connector diagrams are as viewed from the mating end.

14.1. Intelligent transmitters: 15-pin male high-density D-sub

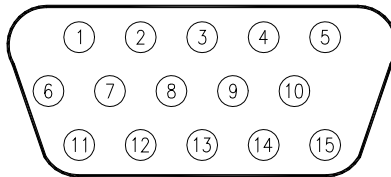

DB15M-HD

PIN	INTELLIGENT TRANSMITTER SIGNAL
1	Chassis ground or Not used (consult SCD)
2	RS-232 TX
3	RS-232 RX
4	Not used
5	Power/signal ground
6	Tare output
7	Tare switch input
8	Overpressure output
9	Power (consult SCD)
10	Not used
11	Not used
12	RS-485 RX+
13	RS-485 RX-
14	RS-485 TX+
15	RS-485 TX-

Figure 5: DB15HD-M Transmitter Connector Pinout

14.2. Intelligent Depth Sensor connectors

14.2.1. Intelligent absolute depth sensors: Burton 5507-1508-000X

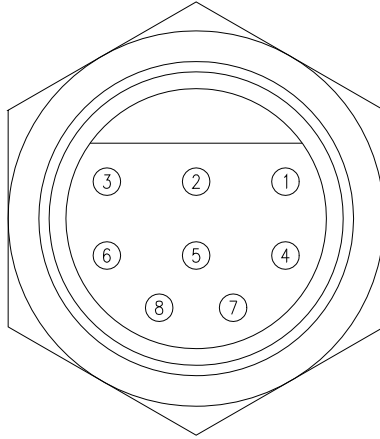

BURTON 5507-1508-000X

PIN	DEPTH SENSOR SIGNAL
1	RS-232 TX
2	RS-232 RX
3	Power/signal ground
4	Power (consult SCD)
5	RS-485 RX+
6	RS-485 RX-
7	RS-485 TX+
8	RS-485 TX-

Figure 6: Burton 5507-1508-000X Connector Pinout

14.2.2. Intelligent gauge depth sensors: Burton 5999-0962-002

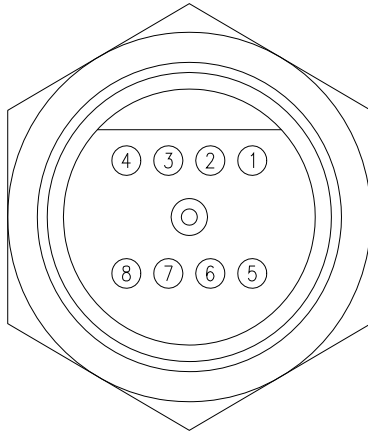

BURTON 5999-0962-002

PIN	DEPTH SENSOR SIGNAL
1	RS-232 TX
2	RS-232 RX
3	Power/signal ground
4	Power (consult SCD)
5	RS-485 RX+
6	RS-485 RX-
7	RS-485 TX+
8	RS-485 TX-

Figure 7: Burton 5999-0962-002 Connector Pinout

14.3. Model 715 connectors

14.3.1. Model 715 15-pin female high-density D-sub

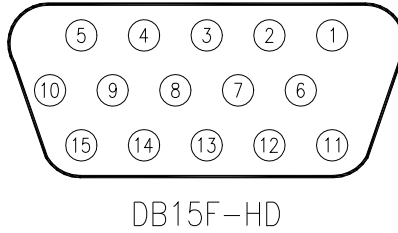

PIN	MODEL 715 RS-232/RS-485 SIGNAL
1	Chassis ground
2	RS-232 TX
3	RS-232 RX
4	Not used
5	Power/signal ground
6	Tare output
7	Tare switch input
8	Overpressure output
9	Power (consult SCD)
10	Not used
11	Not used
12	RS-485 TX+
13	RS-485 TX-
14	RS-485 RX+
15	RS-485 RX-

Figure 8: DB15HD-F Model 715 Connector Pinout

14.3.2. Model 715: 9-pin female D-sub

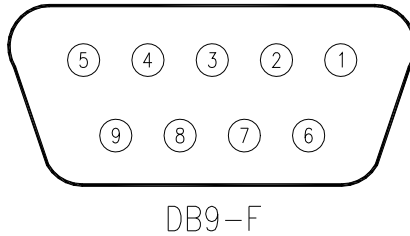

PIN	MODEL 715 RS-232 SIGNAL
1	Chassis ground
2	RS-232 TX
3	RS-232 RX
4	Not used
5	Signal ground
6	Not used
7	Not used
8	Not used
9	Not used

Figure 9: DB9-F Model 715 Connector Pinout

14.4. Power Adapter Module connectors

14.4.1. Power Module 15-pin female high-density D-sub

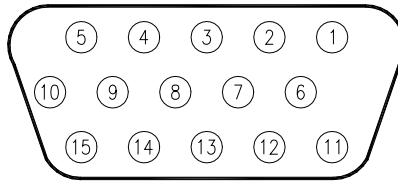

DB15F-HD

PIN	SIGNAL
1	Not used
2	RS-232 TX
3	RS-232 RX
4	Not used
5	Power / signal ground
6	Not used
7	Not used
8	Not used
9	Power (consult SCD)
10	Not used
11	Not used
12	RS-485 RX+
13	RS-485 RX-
14	RS-485 TX+
15	RS-485 TX-

Figure 10: DB15HD-F 6671-003 Power Module Connector Pinout

14.4.2. Power Module 9-pin female D-sub

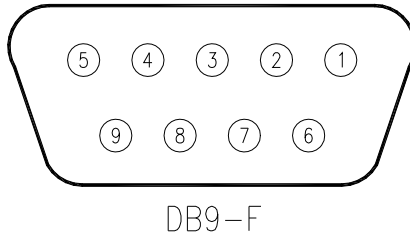

PIN	SIGNAL
1	Not used
2	RS-232 TX
3	RS-232 RX
4	Not used
5	Power / signal ground
6	Not used
7	Not used
8	Not used
9	Power (consult SCD)

Figure 11: DB9-F 6671-003 Power Module Connector Pinout

14.5. PC RS-232 port: 9-pin male D-sub connector

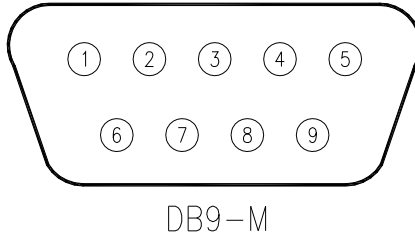

PIN	PC RS-232 SIGNAL
1	Data Carrier detect (DCD)
2	RS-232 RX
3	RS-232 TX
4	Data Terminal Ready (DTR)
5	Signal ground
6	Data Set Ready (DSR)
7	Request To Send (RTS)
8	Clear To Send (CTS)
9	Ring Indicator (RI)

Figure 12: DB9-M PC RS-232 Connector Pinout

15. Serial Wiring Diagrams

The diagrams in this section show the various ways in which DIGIQUARTZ Intelligent devices can be connected to RS-232 and RS-485 serial hosts and the Model 715 display. The pin numbers given are for DIGIQUARTZ Intelligent devices with 15-pin high-density D-subminiature connectors. Refer to Section 14 for pin assignments of other connectors. PC serial port pin numbers assume a typical 9-pin RS-232 port; consult the documentation that came with your PC to verify your RS-232 port pin assignments.

15.1. RS-232 wiring diagrams

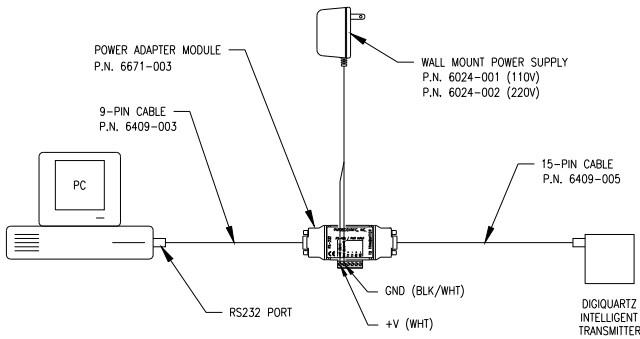

Figure 13: RS-232 Wiring Diagram Using Optional RS232/RS485 Power Module Kit

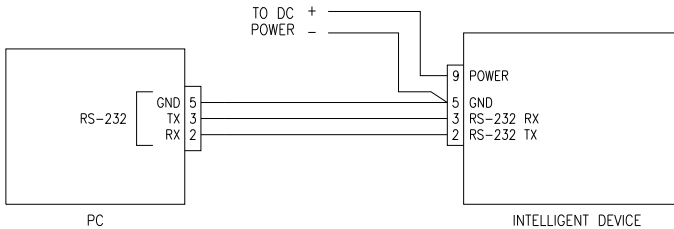

Figure 14: Simple RS-232 Wiring Diagram

15.2. RS-232 serial loop network wiring diagram

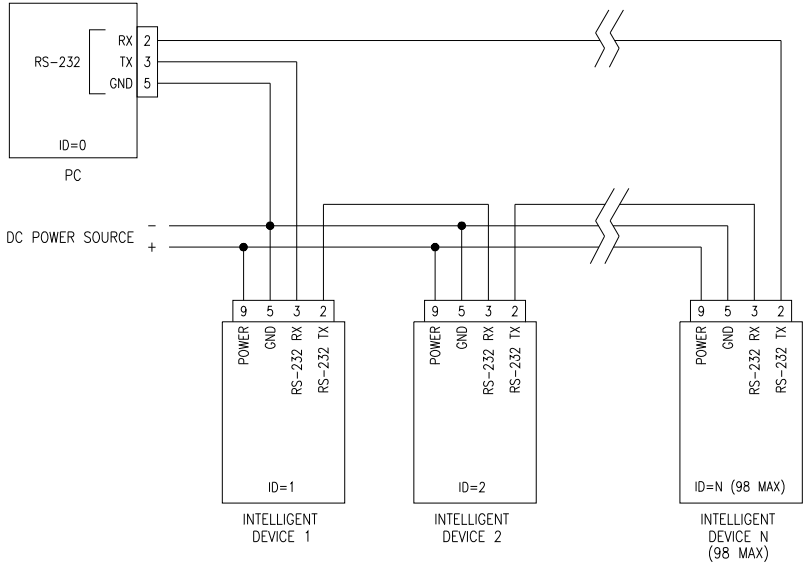

Figure 15: RS-232 Serial Loop Network

15.3. RS-485 wiring diagrams

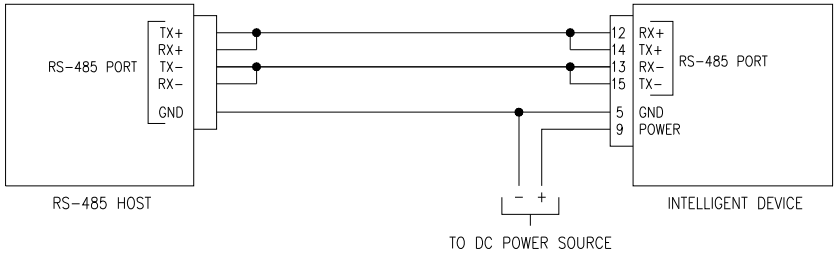

Figure 16: 2-wire RS-485 System, Single Device

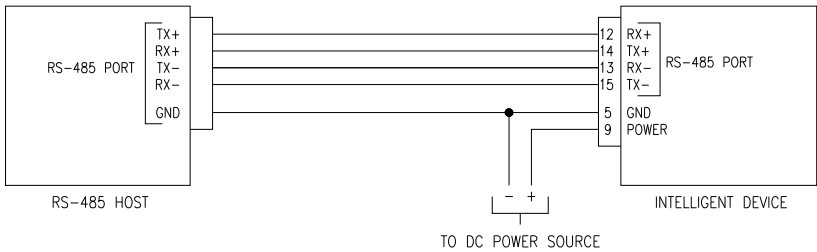

Figure 17: 4-wire RS-485 System, Single Device

15.4. RS-485 multi-drop network wiring diagrams

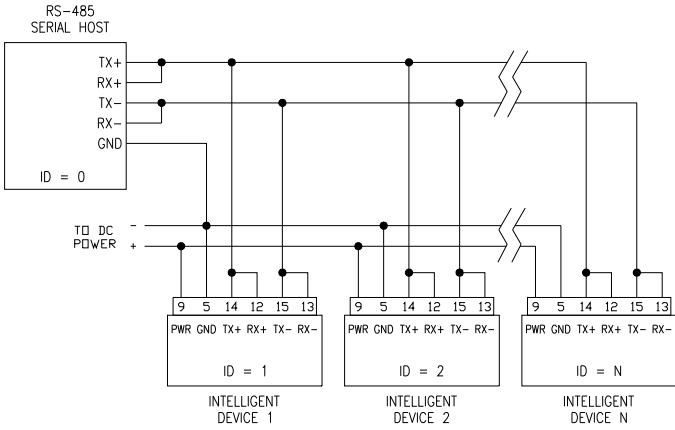

Figure 18: 2-wire RS-485 Multi-drop Network

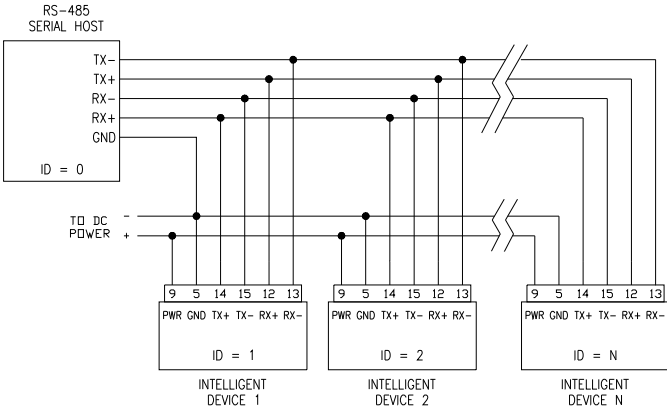

Figure 19: 4-wire RS-485 Multi-drop Network

15.5. Model 715 Display wiring diagrams

The following diagrams illustrate a few typical Model 715 systems. There are two ways to power the Model 715: using an optional wall power supply or via screw terminal blocks. Both methods are shown on each diagram, but only one power option is needed, and either can be selected depending on your application.

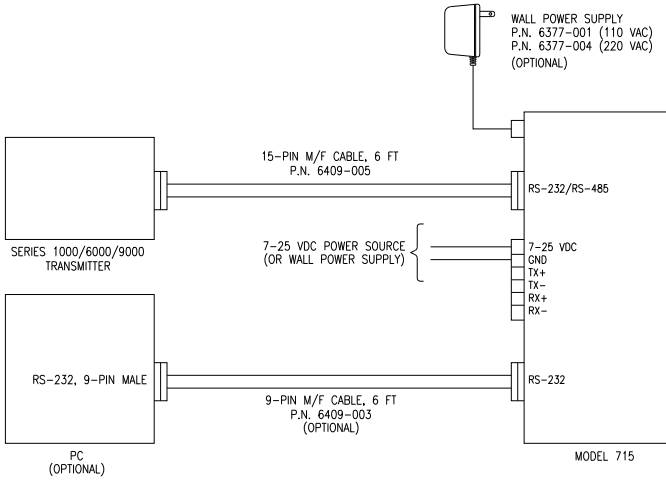

Figure 20: Simple Model 715 / Intelligent Transmitter System w/ Optional PC Shown

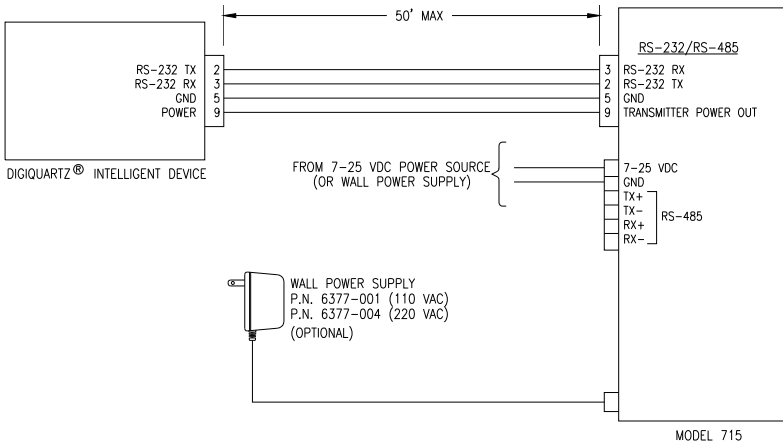

Figure 21: Model 715, RS-232 Connection to an Intelligent Device

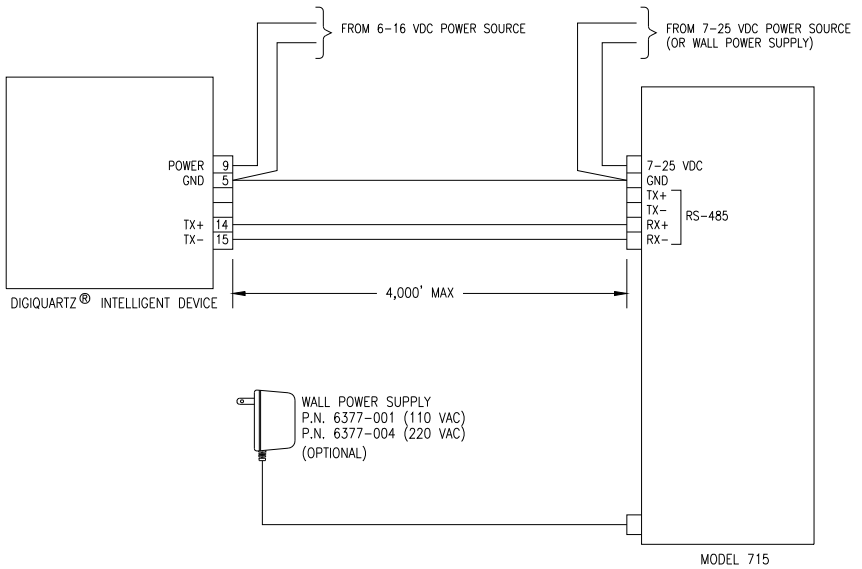

Figure 22: Model 715, RS-485 Connection to an Intelligent Device

16. Troubleshooting

The following are solutions to frequently encountered problems. If you are experiencing difficulty with a DIGIQUARTZ Intelligent device, it is likely that the solution can be found below.

PROBLEM: NO RESPONSE FROM DEVICE

1. Check your connections

- Check your connections to ensure that your system is hooked up properly.
- Check your power source to ensure that the proper voltage is supplied to the device.
- If you believe that your system is wired and powered properly, but you still cannot communicate with your device(s), try using a PC and DIGIQUARTZ Interactive software (DQI) to verify operation and configuration of each device individually. To do this, you will need to connect each device one at a time to the PC RS-232 port. DQI will allow you to establish communications with DIGIQUARTZ Intelligent devices regardless of baud rate or ID settings.

If you are networking your devices, make sure that all are set to the same baud rate, and that any earlier-generation (RS-232 only) devices are set to **PT=N** (8 data bits, no parity, 1 stop bit). Also ensure that each device is set to a unique ID value.

If your device(s) work properly with DQI, but you are still unable to communicate with them in your system, the problem is almost certainly caused by your serial host hardware/software settings or your connections.

2. Check your serial host

- Make sure your serial host is configured for the proper baud rate, and 8 data bits, no parity, and 1 stop bit.
- Make sure your commands are terminated with a carriage return and line feed (ASCII 13 and 10). Your serial host hardware or software may need to be configured to provide proper command termination.
- Make sure that you are sending commands to the proper ID. If you are unsure which ID to use, try sending a global **SN** command (*9900SN), and check the response(s) to see which ID(s) responded.

PROBLEM: INTELLIGENT DEVICE DOES NOT RESPOND TO A COMMAND, BUT RESPONDS TO SUBSEQUENT COMMANDS

- The Intelligent device is probably asleep when the first command is received, but is awake when the second command arrives. Therefore, the first command is ignored, and the second command is acted upon. To avoid this, either wake up the device before attempting a command, or disable sleep mode. Refer to the **SL** command for more information.

17. Internal Calculations and Formulas

DIGIQUARTZ Intelligent devices calculate internal sensor temperature and applied pressure from period measurements of two frequency signals. The equations and coefficients used to perform these calculations are given below. The coefficients are factory-set, and are stored in non-volatile EEPROM. Refer to Section 7.5 for more information.

TEMPERATURE CALCULATION

The following equation is used to calculate internal sensor temperature:

$$T = Y_1U + Y_2U^2 + Y_3U^3$$

Where: T = Temperature (°C)

U = temperature period (microseconds) – U₀ (microseconds)

Temperature coefficients: U₀ Y₁ Y₂ Y₃

PRESSURE CALCULATION

The following equation is used to calculate pressure:

$$P = C(1 - T_0^2/\text{Tau}^2)[1 - D(1 - T_0^2/\text{Tau}^2)]$$

Where: P = pressure

Tau = pressure period (microseconds)

U = temperature period (microseconds) – U₀ (microseconds)

C = C₁ + C₂U + C₃U²

D = D₁ + D₂U

T₀ = T₁ + T₂U + T₃U² + T₄U³ + T₅U⁴

Pressure coefficients: C₁ C₂ C₃ D₁ D₂ T₁ T₂ T₃ T₄ T₅

FINAL OUTPUT PRESSURE CALCULATION

The following equation is used with the pressure value calculated above to calculate the final output pressure value:

$$P_{\text{output}} = \mathbf{PM}[(\text{units multiplier}) \times P + \mathbf{PA}]$$

Where: P_{output} = Final output pressure value (psi)

P = raw pressure value (from pressure equation above)

PM = Value stored in the **PM** parameter

PA = Value stored in the **PA** parameter

Units multiplier = Value used to convert psi to the current pressure unit.
Refer to Section 7.2.3 for more information.

The **PM** and **PA** parameters allow you to make minor zero and span adjustments to the raw pressure value. Normally, **PM** (pressure multiplier) is set to 1.0, and **PA** (pressure adder) is set to 0.0. Refer to Sections 7.5 and 18 for more information.

18. Zero and Span Adjustments

The **PM** and **PA** commands allow you to make minor zero and span adjustments to the raw pressure value. Normally, **PM** (pressure multiplier) is set to 1.0, and **PA** (pressure adder) is set to 0.0.

Adjusted pressure is calculated using the following equation:

$$P_{\text{adjusted}} = \mathbf{PM} \times (P + \mathbf{PA})$$

Where: P = Pressure calculated using original calibration coefficients, in the current pressure units

PM = the current value of PM

PA = the current value of PA

Refer to Sections 7.5 and 17 for more information regarding **PA** and **PM**.

CAUTION Use extreme caution when modifying **PA** or **PM** because they directly affect calibration. Inaccurate values will result in inaccurate pressure measurements.

This page intentionally left blank.

19. Command and Parameter Reference

COMMANDS	PAGE
BL Lock baud rate.....	7-16
BR Set baud rate.....	7-15
CS Check stack.....	7-36
DB Dump buffer.....	7-3
DS Dump sequential.....	7-3
DT Display text on second line of Model 715.....	7-32
EW Enable write.....	7-14
ID Set ID.....	7-17
M1 Minimum pressure value.....	7-7
M3 Maximum pressure value.....	7-7
MR Reset minimum and maximum pressure values.....	7-7
OF Execute user defined command(s).....	7-13
P1 Measure single pressure period.....	7-1
P2 Continuously measure pressure period.....	7-4
P3 Measure single pressure.....	7-1
P4 Continuously measure pressure.....	7-4
P5 Sample and hold pressure.....	7-2
P6 Sample and hold pressure period.....	7-2
P7 Continuously measure pressure at maximum rate.....	7-5
Q1 Measure single temperature period.....	7-1
Q2 Continuously measure temperature period.....	7-6
Q3 Measure single temperature.....	7-2
Q4 Continuously measure temperature.....	7-6
Q5 Sample and hold temperature.....	7-2
Q6 Sample and hold temperature period.....	7-3
PARAMETERS	PAGE
C1 C1 coefficient.....	7-38
C2 C2 coefficient.....	7-38
C3 C3 coefficient.....	7-38
CF Firmware checksum.....	7-27
D1 D1 coefficient.....	7-38
D2 D2 coefficient.....	7-38
DL Data logger (fixed field format) mode.....	7-26
DM Display mode.....	7-30
DO Display output port.....	7-31
DP Decimal point (Decimal places in displayed pressure value)....	7-31
FM Fetch mode enable/disable.....	7-10
IA IIR mode cutoff frequency.....	8-2

PARAMETERS (CONTINUED)**PAGE**

MD	Serial data mode.....	7-34
MN	Model number.....	7-28
OI	Sequential / Simultaneous integration mode.....	7-9
OM	User-defined command definition(s).....	7-13
OP	Overpressure alarm setpoint.....	7-23
PA	Pressure adder.....	7-36
PF	Full-scale pressure.....	7-28
PI	Pressure integration time.....	7-8
PL	Pressure limit (Overpressure setpoint for Model 715 display)....	7-32
PM	Pressure multiplier.....	7-37
PO	Pressure transducer type.....	7-28
PR	Pressure resolution.....	7-9
PS	Temperature measurement interval (used w/ P7 command).....	7-5
SL	Sleep mode enable/disable.....	7-20
SN	Serial number.....	7-27
ST	Sleep timeout.....	7-20
SU	Data separation character enable/disable.....	7-25
T1	T1 coefficient.....	7-38
T2	T2 coefficient.....	7-38
T3	T3 coefficient.....	7-38
T4	T4 coefficient.....	7-38
T5	T5 coefficient.....	7-38
TC	Timebase correction factor.....	7-37
TI	Temperature integration time.....	7-8
TR	Temperature resolution.....	7-9
TU	Temperature unit (C/F).....	7-19
TS	Time reference stamp enable/disable.....	7-29
U0	U0 coefficient.....	7-38
UF	User-defined unit factor.....	7-19
UL	Text to display on line 2 of Model 715.....	7-33
UM	User-defined unit label.....	7-27
UN	Pressure unit.....	7-18
US	Serial data unit suffix.....	7-24
VR	Firmware version.....	7-27
XM	Resolution mode.....	8-2
XN	Number of significant digits.....	8-6
XT	Number of temperature readings to average in FIR mode.....	8-5
Y1	Y1 coefficient.....	7-38
Y2	Y2 coefficient.....	7-38
Y3	Y3 coefficient.....	7-38
ZI	Tare serial indication.....	7-25
ZL	Tare lock.....	7-22
ZS	Tare switch state.....	7-21
ZV	Tare offset value.....	7-22

NOTES

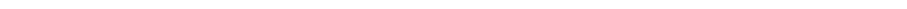

Paroscientific, Inc.
4500 148th Avenue N.E.
Redmond, WA 98052, USA
Tel: (425) 883-8700
Fax: (425) 867-5407

www.paroscientific.com

E-MAIL: support@paroscientific.com

Doc. Number 8819-001 Rev. R
©PAROSCIENTIFIC, INC. AUG 2010